

**TECHNICAL MANUAL  
OPERATOR'S, ORGANIZATIONAL, AND DIRECT SUPPORT  
MAINTENANCE MANUAL (INCLUDING REPAIR  
PARTS AND SPECIAL TOOLS LIST)**

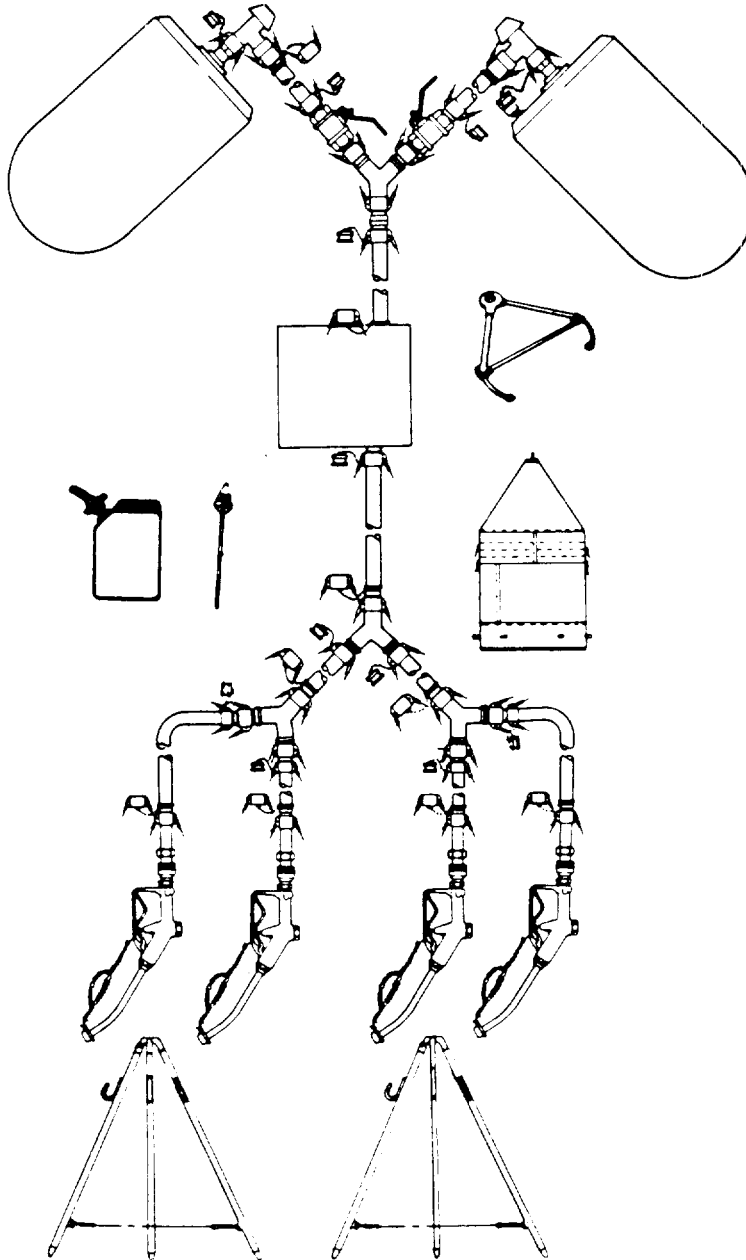

INTRODUCTION

OPERATING INSTRUCTIONS

OPERATOR MAINTENANCE  
INSTRUCTIONS

ORGANIZATIONAL  
MAINTENANCE INSTRUCTIONS

DIRECT SUPPORT  
MAINTENANCE INSTRUCTIONS

APPENDIX A REFERENCES

APPENDIX B MAINTENANCE  
ALLOCATION CHART

APPENDIX C REPAIR PARTS  
AND SPECIAL TOOLS LIST

APPENDIX D EXPENDABLE  
SUPPLIES AND MATERIALS LIST

APPENDIX E TORQUE LIMITS

**FORWARD AREA WATER  
POINT SUPPLY SYSTEM  
MODEL WPSS100**

**NSN: 4320-01-168-1629**

**HEADQUARTERS, DEPARTMENT OF THE ARMY**

**6 JANUARY 1986**



HEADQUARTERS,  
DEPARTMENT OF THE ARMY AND  
HEADQUARTERS, U.S. MARINE CORPS  
WASHINGTON, D.C., 31 July 1996

CHANGE

NO. 8

Operator's, Organizational, and Direct Support  
Maintenance Manual (Including Repair Parts  
and Special Tools List)

**FORWARD AREA WATER POINT SUPPLY SYSTEM (FAWPSS)  
MODEL WPSS100  
(NSN 4320-01-168-1629)**

**AND**

**MODEL 9095-91  
(NSN 4320-01-338-3305)**

DISTRIBUTION STATEMENT A: Approved for public release; distribution is unlimited.

TM 5-4320-301-13&P/TM 08936A-13&P/1, 6 January 1986, is changed as follows:

1. Remove and insert pages as indicated below. New or changed text material is indicated by a vertical bar in the margin. An illustration change is indicated by a miniature pointing hand.

Remove pages

i and ii  
1-1 through 1-7/(1-8 blank)  
2-9 through 2-16  
3-3 and 3-4  
4-3 through 4-6  
4-9 and 4-10  
4-13 through 4-20  
4-20.1 and 4-20.2  
4-21/(4-22 blank)  
5-3 through 5-8  
C-15 and C-16  
C-21 through C-23/(C-24 blank)  
C-25 through C-32  
D-1 and D-2  
F-1 through F-4

Insert pages

i and ii  
1-1 through 1-7/(1-8 blank)  
2-9 through 2-16  
3-3 and 3-4  
4-3 through 4-6  
4-9 and 4-10  
4-13 through 4-20  
4-20.1 and 4-20.2  
4-21/(4-22 blank)  
5-3 through 5-8  
C-15 and C-16  
C-21 through C-23/(C-24 blank)  
C-25 through C-32  
D-1 and D-2  
F-1 through F-4

2. Retain this sheet in front of manual for reference purposes.

By Order of the Secretaries of the Army and Navy (including the Marine Corps):

Official:

  
JOEL B. HUDSON  
*Administrative Assistant to the  
Secretary of the Army*  
02331

DENNIS J. REIMER  
*General, United States Army  
Chief of Staff*

J. E. BUFFINGTON  
*Rear Admiral, CEC, US Navy  
Commander  
Navy Facilities Engineering  
Command*

D. R. BLOOMER  
*Colonel, USMC  
Director, Program Support  
Marine Corps Systems Command*

**DISTRIBUTION:**

To be distributed in accordance with DA Form 12-25-E, block no. 2446, requirements for  
TM 5-4320-301-13&P.

CHANGE

HEADQUARTERS  
DEPARTMENT OF THE ARMY  
AND HEADQUARTERS U.S. MARINE CORPS  
WASHINGTON, D.C., 29 JULY 1994

No. 7

Operator's, Organizational, and Direct Support  
Maintenance Manual (Including Repair Parts  
and Special Tools List)

FORWARD AREA WATER POINT SUPPLY SYSTEM (FAWPSS)  
MODEL WPSS100 (NSN: 4320-01-168-1629)  
AND  
MODEL 9095-91 (NSN: 4320-01-338-3305)

DISTRIBUTION STATEMENT A: Approved for public release; distribution is unlimited.

TM 5-4320-301-13&P/TM 08936A-13&P/1, 6 January 1986, is changed as follows:

1. Remove and insert pages as indicated below. New or changed text material is indicated by a vertical bar in the margin. An illustration change is indicated by a miniature pointing hand.

Remove pages

C-27 and C-28

C-31 and C-32

F-1 through F-4

Insert pages

C-27 and C-28

C-31 and C-32

F-1 through F-4

2. Retain this sheet in front of manual for reference purposes.

By Order of the Secretaries of the Army and Air Force (Including the Marine Corps):

Official:

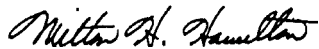

**MILTON H. HAMILTON**

*Administrative Assistant to the  
Secretary of the Army*

07143

**GORDON R. SULLIVAN**  
*General, United States Army  
Chief of Staff*

**MERRILL A. McPEAK**  
*General, USAF  
Chief of Staff*

**RONALD W. YATES**  
*General, USAF  
Commander Air Force Materiel Command*

**D. R. BLOOMER**  
*Colonel, USMC  
Director Program Support  
Marine Corps Systems Command*

**DISTRIBUTION:**

To be distributed in accordance with DA Form 12-25-E, block no. 2446, requirements for  
TM 5-4320-301-13&P.

CHANGE

HEADQUARTERS  
DEPARTMENT OF THE ARMY  
AND HEADQUARTERS U.S. MARINE CORPS  
WASHINGTON, D.C., 28 MAY 1993

NO. 6

Operator's, Organizational, and Direct Support  
Maintenance Manual (Including Repair Parts  
and Special Tools List)

FORWARD AREA WATER POINT SUPPLY SYSTEM (FAWPSS)  
MODEL WPSS100 (NSN: 4320-01-168-1629)  
AND  
MODEL 9095-91 (NSN: 4320-01-338-3305)

DISTRIBUTION STATEMENT A: Approved for public release; distribution is unlimited.

TM 5-4320-301-13&P/TM 08936A-13&P/1, 6 January 1986, is changed as follows:

1. Remove and insert pages as indicated below. New or changed text material is indicated by a vertical bar in the margin. An illustration change is indicated by a miniature pointing hand.

Remove pages

i and ii  
C-1 through C-22

Insert pages

i and ii  
C-1 through C-32

2. Retain this sheet in front of manual for reference purposes.

**By Order of the Secretaries of the Army and Navy (Including the Marine Corps):**

**GORDON R. SULLIVAN**  
*General, United States Army*  
*Chief of Staff*

Official:

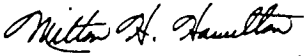
  
**MILTON H. HAMILTON**  
*Administrative Assistant to the*  
*Secretary of the Army*

04358

**H. E. REESE**  
*Deputy for Support*  
*Marine Corps Research, Development and*  
*Acquisition Command*

**RONALD D. ELLIOT**  
*Executive Director*  
*Marine Corps Systems Command*

**W. T. LELAND**  
*Rear Admiral*  
*Chief, Office Law*  
*Enforcement and Defense Operations*  
*United States Coast Guard*

**DISTRIBUTION:**

To be distributed in accordance with DA Form 12-25-E, block no. 2446, requirements for  
TM 5-4320-301-13&P .



CHANGE

HEADQUARTERS  
DEPARTMENT OF THE ARMY  
AND HEADQUARTERS U.S. MARINE CORPS  
WASHINGTON, D.C., 22 MARCH 1993

NO. 5

Operator's, Organizational, and Direct Support  
Maintenance Manual (Including Repair Parts  
and Special Tools List)

FORWARD AREA WATER POINT SUPPLY SYSTEM (FAWPSS)  
MODEL WPSS100 (NSN: 4320-01-168-1629)  
AND  
MODEL 9095-91 (NSN: 4320-01-338-3305)

DISTRIBUTION STATEMENT A: Approved for public release; distribution is unlimited.

TM 5-4320-301-13&P/TM 08936A-13&P/1, 6 January 1986, is changed as follows:

1. Remove and insert pages as indicated below. New or changed text material is indicated by a vertical bar in the margin. An illustration change is indicated by a miniature pointing hand.

Remove pages

i and ii  
1-1 and 1-2  
2-3 through 2-8  
-----  
4-3 through 4-8  
-----  
B-1 through B-5/(B-6 blank)  
C-17 and C-18  
F-3 and F-4

Insert pages

i and ii  
1-1 and 1-2  
2-3 through 2-7/(2-8 blank)  
3-7/(3-8 blank)  
4-3 through 4-6  
4-20.1 and 4-20.2  
B-1 through B-5/(B-6 blank)  
C-17 and C-18  
F-3 and F-4

2. Retain this sheet in front of manual for reference purposes.

TM 5-4320-301-13&P

TM 08936A-13&P/1

C 5

By Order of the Secretary of the Army:

Official:

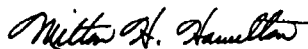

MILTON H. HAMILTON  
*Administrative Assistant to the  
Secretary of the Army*

04244

GORDON R. SULLIVAN  
*General, United States Army  
Chief of Staff*

**DISTRIBUTION:**

To be distributed in accordance with DA Form 12-25-E, block no. 2446, requirements for TM 5-4320-301-13&P.

CHANGE

HEADQUARTERS,  
DEPARTMENT OF THE ARMY  
AND HEADQUARTERS U.S. MARINE CORPS  
WASHINGTON, D.C., 21 AUGUST 1991

NO. 4

Operator's, Organizational, and Direct Support  
Maintenance Manual (Including Repair Parts  
and Special Tools List)

**FORWARD AREA WATER POINT SUPPLY SYSTEM (FAWPSS)  
MODEL WPSS100 (NSN: 4320-01-168-1629)  
AND  
MODEL 9095-91 (NSN: 4320-01-338-3305)**

Approved for public release; distribution is unlimited

TM 5-4320-301-13&P/TM 08936A-13&P/1, 6 January 1986, is changed as follows:

1. Remove and insert pages as indicated below. New or changed text material is indicated by a vertical bar in the margin. An illustration change is indicated by a miniature pointing hand.

**Remove pages**

i and ii  
1-1 through 1-4  
2-1 and 2-2  
2-5 through 2-10  
2-15 through 2-19/(2-20 blank)  
3-1 and 3-2  
4-3 through 4-6  
4-9 and 4-10  
A-1/(A-2 blank)  
B-5/(B-6 blank)  
C-9 and C-10  
C-13 through C-20  
F-3 and F-4

**Insert pages**

i and ii  
1-1 through 1-4  
2-1 and 2-2  
2-5 through 2-10  
2-15 through 2-19/(2-20 blank)  
3-1 and 3-2  
4-3 through 4-6  
4-9 and 4-10  
A-1/(A-2 blank)  
B-5/(B-6 blank)  
C-9 and C-10  
C-13 through C-20  
F-3 and F-4

2. Retain this sheet in front of manual for reference purposes.

TM 5-4320-301-13&P  
TM 08936A-13&P/1  
C 4

By Order of the Secretaries of the Army and Navy (Including the Marine Corps):

**GORDON R. SULLIVAN**  
*General, United States Army*  
*Chief of Staff*

Official:

**PATRICIA P. HICKERSON**  
*Brigadier General, United States Army*  
*The Adjutant General*

**DAVID E. BOTTORFF**  
*Rear Admiral, CEC, US Navy*  
*Commander*  
*Navy Facilities Engineering Command*

**H.E. REESE**  
*Deputy for Support*  
*Marine Corps Research, Development and*  
*Acquisition Command*

DISTRIBUTION:

To be distributed in accordance with DA Form 12-25E (qty rqr block no. 2446)

CHANGE

NO. 3

HEADQUARTERS  
DEPARTMENT OF THE ARMY  
WASHINGTON, D.C., 12 March 1991

Operator's, Organizational, and Direct Support  
Maintenance Manual Including  
Repair Parts and Special Tools List

FORWARD AREA WATER POINT SUPPLY SYSTEM (FAWPSS)  
MODEL WPSS100  
NSN 4320-01-168-1629

Approved for public release; distribution is unlimited

TM 5-4320-301-13&P/TM 08936A-13&P/1, 6 January 1986, is changed as follows:

1. Remove and insert pages as indicated below. New or changed text material is indicated by a vertical bar in the margin. An illustration change is indicated by a miniature pointing hand.

Remove pages

i and ii  
1-1 and 1-2  
---

Insert pages

i and ii  
1-1 and 1-2  
F-1 through F-4

2. Retain this sheet in front of manual for reference purposes.

By Order of the Secretary of the Army:

**CARL E. VUONO**  
*General, United States Army*  
*Chief of Staff*

Official:

**THOMAS F. SIKORA**  
*Brigadier General, United States Army*  
*The Adjutant General*

DISTRIBUTION:

To be distributed in accordance with DA Form 12-25E, (qty rqr block no. 2446)



CHANGE }  
No. 2 }

HEADQUARTERS  
DEPARTMENT OF THE ARMY  
WASHINGTON, D.C., 18 January 1990

Operator's, Organizational, and Direct Support Maintenance Manual  
(Including Repair Parts and Special Tools List)

FORWARD AREA WATER POINT SUPPLY SYSTEM  
MODEL WPSS100 NSN: 4320-01-168-1629

Approved for public release; distribution is unlimited.

TM 5-4320-301-13&P, 6 January 1986, is changed as follows:

1. Remove and insert pages as indicated below. New or changed text material is indicated by a vertical bar in the margin. An illustration change is indicated by a miniature pointing hand.

Remove pages

A-1/A-2

Insert pages

A-1/A-2

2. Retain this sheet in front of manual for reference purposes.

**By Order of the Secretary of the Army:**

**JOHN A. WICKHAM, JR.**  
*General, United States Army*  
*Chief of Staff*

**Official:**

**THOMAS F. SIKORA**  
*Brigadier General, United States Army*  
*The Adjutant General*

**DISTRIBUTION:**

To be distributed in accordance with DA Form 12-25A, Operator, Unit and Direct Support Maintenance requirements for Pump, Centrifugal, gas Driven, Frame Mounted, 125 GPM, 50 FT Head, 2 IN (2-125-50-G)





CHANGE }  
No. 1 }

HEADQUARTERS  
DEPARTMENT OF THE ARMY  
WASHINGTON, D.C., 2 January 1987

Operator's, Organizational, and Direct Support Maintenance Manual  
(Including Repair Parts and Special Tools List)

FORWARD AREA WATER POINT SUPPLY SYSTEM  
MODEL WPSS100 NSN: 4320-01-168-1629

TM 5-4320-301-13&P, 6 January 1986, is changed as follows:

1. Remove and insert pages as indicated below. New or changed text material is indicated by a vertical bar in the margin. An illustration change is indicated by a miniature pointing hand.

Remove pages

C-19/C-20

Insert pages

C-19 through C-22

2. Retain this sheet in front of manual for reference purposes.

**By Order of the Secretary of the Army:**

**JOHN A. WICKHAM, JR.**  
*General, United States Army*  
*Chief of Staff*

**Official:**

**R. L. DILWORTH**  
*Brigadier General, United States Army*  
*The Adjutant General*

**DISTRIBUTION:**

To be distributed in accordance with DA Form 12-25A, Operator, Organizational, Direct Support and General Support Maintenance requirements for Pump, Centrifugal, Frame Mounted, 125 GPM.



**WARNING**

Never operate the centrifugal pump in an enclosed area unless the exhaust gases are piped to the outside. Exhaust gases contain carbon monoxide which is a colorless, odorless, and poisonous gas.

**WARNING**

Make sure spark plug leads are disconnected before performing maintenance on the pump. This does not apply to diesel engines.

**WARNING**

Avoid breathing smoke when using a fire extinguisher.

**WARNING**

Do not fill the fuel tank while the engine is running. Gasoline spilled on a hot engine may explode and cause serious injury to personnel. This does not apply to diesel engines.

**WARNING**

Make sure all gasoline fumes are removed from tank before starting welding operations. Fumes in tank can cause a severe explosion if ignited. This does not apply to diesel engines.

**WARNING**

Dry-cleaning solvent, P-D-680, used to clean parts is potentially dangerous to personnel and property. Avoid inhalation of fumes and repeated or prolonged skin exposure. Wash exposed skin thoroughly with soap and water. Use in well ventilated area away from open flame or excessive heat. Flash point is 100°F (38° C).



TECHNICAL MANUAL

NO. 5-4320-301-13&P

HEADQUARTERS  
 DEPARTMENT OF THE ARMY AND  
 HEADQUARTERS U.S. MARINE CORPS  
 WASHINGTON, D.C, 6 January 1986

Operator's, Organizational, and Direct Support  
 Maintenance Manual Including Repair Parts and  
 Special Tools List  
 Forward Area Water Point Supply System (FAWPSS)  
 Model WPSS100 (NSN 4320-01-168-1629)  
 and  
 Model 9095-91 (NSN: 4320-01-338-3305)

Current as of 4 March 1993

**REPORTING ERRORS AND RECOMMENDING IMPROVEMENTS**

**ARMY**

You can help improve this manual. If you find any mistakes, or if you know of a way to improve these procedures, please let us know. Mail your letter or DA Form 2028 (Recommended Changes to Publications and Blank Forms), or DA Form 20282 located in the back of this manual directly to: Commander, US Army Aviation and Troop Command, ATIN: AMSATIMP, 4300 Goodfellow Blvd., St. Louis, MO 631201798. You may also submit your recommended changes by Email directly to <mpmt%avma28@stlouisemh7.army.mil>. A reply will be furnished directly to you. Instructions for sending an electronic 2028 may be found at the back of this manual immediately preceding the hard copy 2028.

**MARINE CORPS**

Commander. ATTN: (Code 850). Marine Corps Logistics Bases. 814 Radford Blvd.. Albany. GA 31704-1128.

**DISTRIBUTION STATEMENT A:** Approved for public release; distribution is unlimited.

**TABLE OF CONTENTS**

		Para	Page
<b>CHAPIER 1</b>	<b>INTRODUCTION</b>		
Section I.	General Information .....	1-1	1-1
II.	Equipment Description and Data.....	1-8	1-3
III.	Technical Principles of Operations.....	1-12	1-7
<b>CHAPER 2</b>	<b>OPERATING INSTRUCTIONS</b>		
Section I.	Description and Use of Operator's Controls and Indicators.....	2-1	2-1
II.	Operator's Preventive Maintenance Checks and Service (PMCS).....	2-3	2-4
III.	Operation Under Usual Conditions.....	2-5	2-9
IV.	Operation Under Unusual Conditions.....	2-10	2-17
<b>CHAPIER 3</b>	<b>OPERATOR MAINTENANCE INSTRUCIIONS</b>		
Section I.	Lubrication Instructions .....	3-1	3-1
II.	Operator Troubleshooting .....	3-2	3-1
III.	Operator Maintenance Procedures .....	3-3	3-3

TABLE OF CONTENTS (Continued)

		Para	Page
CHAPTER	4 .	ORGANIZATIONAL MAINTENANCE INSTRUCTIONS	
Section	I.	Service Upon Receipt . . . . .	4-1 4-1
	II.	Repair Parts, Special Tools, TMDE, and Support Equipment . .	4-3 4-4
	III.	Preventive Maintenance Checks and Services . . . . .	4-6 4-5
	IV	Organizational Troubleshooting Procedures . . . . .	4-8 4-9
	V .	Organizational Maintenance Procedures . . . . .	4-10 4-11
CHAPTER	5.	DIRECT SUPPORT MAINTENANCE INSTRUCTIONS	
	I.	Repair Parts, Special Tools, TMDE and Support Equipment ...	5-1 5-1
	II.	Direct Support Maintenance Troubleshooting Table . . . . .	5-4 5-1
	III.	Direct Maintenance Procedures . . . . .	5-5 5-3

LIST OF APPENDICES

		Illus/ Figure	Page
APPENDIX	A.	REFERENCES . . . . .	A-1
	B.	MAINTENANCE ALLOCATION CHART . . . . .	B-1
	C.	OPERATOR'S, UNIT, AND DIRECT SUPPORT REPAIR . . . . .	
		PARTS AND SPECIAL TOOLS LIST... . . . .	C-1
Section	I.	Introduction . . . . .	C-1
Section	II.	Repair Parts List	C-1
		Group 01 Valve Assembly	
		Ball Valve, Quick Acting . . . . . 1	C-9
		Group 02 Nozzle Distribution Assembly	
		Distribution Nozzle, Potable Water . . . . . 2	C-11
		Group 03 Stand Assembly	
		Nozzle Stand Assembly . . . . . 3	C-13
		Group 04 Hose Assembly	
		Hose Assembly, Potable Water . . . . . 4	C-15
		Group 05 Water Drum Assembly	
		Water Fabric Drum . . . . . 5	C-17
		Group 06 Pump Assembly	
		Centrifugal Pumps . . . . . 6	C-19
		Group 07 Towing and Lifting Yoke Assembly	
		Towing and Lifting Yoke Assembly . . . . . 7	C-21
		Group 08 Miscellaneous Items	
		Miscellaneous Parts and Fittings . . . . . 8	C-23
		Group 09 Bulk Materials . . . . . Bulk	C-25
Section	III.	Special Tools List (Not Applicable)	
Section	IV.	Cross-Reference Indexes . . . . .	C-26
		National Stock Number Index . . . . .	C-26
		Part Number Index . . . . .	C-27
		Figure and Item Number Index... . . . .	C-30
	D.	EXPENDABLE SUPPLIES AND MATERIALS LIST . . . . .	D-1
	E.	TORQUE LIMITS . . . . .	E-1
	F.	COMPONENTS OF END ITEM AND BASIC ISSUE ITEMS LIST . . . . .	F-1
INDEX		ALPHABETICAL INDEX . . . . .	INDEX-1

# CHAPTER 1 INTRODUCTION

## Section I GENERAL INFORMATION

### 1-1. SCOPE.

**Type of Manual:** Operator, Organizational, and Direct Support Maintenance.

**Model Number and Equipment Name:** Model WPSS100 & Model 9095-91 Forward Area Water Point Supply System.

**Purpose of Equipment** Provides potable water to troop units in arid regions.

**1-2. MAINTENANCE FORMS AND RECORDS.** Department of the Army form and procedures used for equipment maintenance will be those prescribed by DA PAM 738-750, The Army Maintenance Management System. Marine Corps personnel will prepare and maintain records and report forms as prescribed by TM 4700-15/1.

**1-3. HAND RECEIPT (-HR) MANUALS.** Hand receipts for Components of End Item (COEI). Basic Issue Items (BII), and Additional Authorization List (AAL) items are published in a Hand Receipt manual, TM 54320-301-13-HR. This manual is published to aid in property accountability and is available through The U.S. Army Adjutant General, 2800 Eastern Blvd., Baltimore, MD 21220.

**1-4. REPORTING EQUIPMENT IMPROVEMENT RECOMMENDATIONS (EIR).** If your FAWPSS needs improvement, let us know. Send us an EIR. You the user, are the only one who can tell us what you don't like about your equipment. Let us know why you don't like the design. Put it on an SF 368 (Quality Deficiency Report). Mail it to us at Commanding General, US Army Aviation and Troop Command ATTN: AMSAT-I-MDO, 4300 Goodfellow Blvd., St. Louis, MO 63120-1798. Marine Corps users are encouraged to submit EIRs in accordance with MCO 1650.17 and QDR's using MCO 4855.10.

**1-5. NOMENCLATURE, CROSS-REFERENCE LIST.** This list includes nomenclature and cross-references used in this manual.

<i>Common Name</i>	<i>Official Nomenclature</i>
125 GPM Pump and Engine Assy	125-GPM Pump Assy Including: (1) Quick Disconnect Coupling Half, Cam-Locking Type, Male (2) Quick Disconnect Coupling Half, Cam-Locking Type, Female
500-Gallon Water Drum	Water Storage and Dispensing Drum Assy, Consisting of: (1) Collapsible Fabric Water Storage and Dispensing Drum, 500-Gallon (2) Two-Inch Elbow Coupler Valve Assy

*Common Name*

*Official Nomenclature*

2-Inch Valve Assy

Valve Assy, Consisting of:  
(1) Two-Inch Bronze/Aluminum-Type Threaded Ball Valve  
(2) Quick-Disconnect Coupling Half, Cam-Locking Type, Male  
(3) Quick-Disconnect Coupling Half, Cam-Locking Type, Female

Water Distribution Nozzle Assy

Distribution Nozzle Assy, Consisting of:  
(1) Distribution Nozzle  
(2) Swivel  
(3) Reducer, External Pipe Thread by Quick-Disconnect, Cam Locking Type

Stand Assy

Stand Assy

2-Inch by 10-Foot Discharge Hose Assy

Water Hose Assy, Discharge, Two-Inch Nominal Size, Ten-Foot Length

1 1/2-Inch by 25-Foot Discharge Hose Assy

Water Hose Assy, Discharge, One-and-One-Half-Inch Nominal Size, 25-Foot Length

2-Inch by 25-Foot Discharge Hose Assy

Water Hose Assy, Discharge, Two-Inch Nominal Size, 25-Foot Length

2-Inch by 10-Foot Suction Hose Assy

Water Hose Assy, Suction, Two-Inch Nominal Size, Ten-Foot Length A

2-Inch Y-Connector

Y-Fitting Component

Double Male Adapter

Adapter, Double Male

2-Inch Rubber Gasket

Gasket, Rubber, Flat Two-Inch

1 1/2-Inch Rubber Gasket

Gasket, Rubber, Flat One-and-One-Half-Inch

1 1/2 To 1-Inch Reducer

Reducer, One-and-One-Half-Inch By One-Inch, Male By Female and Female By Male Quick-Disconnect, Cam-Locking Type

5-Gallon Gasoline Can

Can, Gasoline, Utility, 5-Gallon, Sand Color

Spout, Can Flexible

Spout, Can Flexible

**1-2 Change 8**



**1-6. LIST OF ABBREVIATIONS. This list includes abbreviations used in this manual.**

Assy	Assembly
DA PAM	Department of Army Pamphlet
A	Army
M	Marine

**Section II  
EQUIPMENT DESCRIPTION AND DATA**

**1-7. EQUIPMENT DESCRIPTION, CAPABILITIES, AND FEATURES.**

Characteristics

- \* Provides potable water to four nozzles for dispensing water.
- \* Four nozzles individually controlled for dispensing water.

Capabilities and Features

- \* Pumps potable water from two 500-gallon water drums.
- \* Units easily setup and maintained.
- \* Fueled from gas drum or gas can.

**1-8. DESTRUCTION OF ARMY MATERIAL TO PREVENT ENEMY USE.** Department of Army regulations and procedures for destruction of defense equipment to prevent enemy use will be those prescribed in TM 7502443, Procedures for Destruction of Equipment to Prevent Enemy Use (Mobility Equipment Command).

**1-9. PREPARATION FOR STORAGE OR SHIPMENT** For administrative storage of equipment, refer to TM 740901. SB740991 for Army instructions and MCO 4450.7 for Marine Corps. For package discrepancy Marine Corps personnel will submit appropriate Report of Discrepancy (ROD) as prescribed by MCO 4430.3 and on SP361 Discrepancy in Shipment Report (DISREP) as prescribed by MCO P4610.19C for shipment report DISREP.

**1-10. LOCATION AND DESCRIPTION OF MAJOR COMPONENTS.**

*125GPM Pump and Engine Assy.* The 125 GPM pump and engine assy (6) provides power to operate the FAWPSS. The pump provides 125gallons of fresh water per minute at 50foot head. A 5gallmo gas can (15) with a flexible spout (13) is supplied with the engine and pump assy.

*500Gallon Water Drum.* The six 500gallon water drums (1) (used two at a time) are designed for a working pressure of 4 to 5 psi pounds/square inch (0.3 to 0.4 kg/cm)]. When filled to its 500gallon capacity, the water drum (1) is round in shape towing and lifting yoke assy (16). Two elbow coupler valve assys (2) are provided with the 500gallon water drums (1) for ease of connection to the FAWPSS system.

**TM 5-4320-301-13&P**  
**TM 08936A-13&P/1**

*2-Inch Valve Assy.* Two, 2-inch valve assys (4) provide for control of water during installation, operation, and disassembly of the FAWPSS.

*Nozzle Assy.* Four nozzle assys (11) are supplied with the system for dispensing water. Each nozzle assy (11) is equipped with a quick-disconnect connector and a swivel for ease of operation.

*Stand Assy.* Two stand assys (12) are supplied to hang the four nozzle assys (1) on when not in use.

*Hose Assys.* Various quick disconnect, cam-locking hose assys are supplied with the FAWPSS. The quick disconnect connectors provide for ease of assy, disassembly and maintenance. Each hose assy is equipped with a protective cap on one end and a protective plug on the other end to prevent contamination when not in use.

*Y-Connectors.* Four Y-Connectors (5) are supplied with the system. Connectors increase or decrease the amount of water dispensed.

*Double Male Adapter.* One double male adapter (18) is supplied with the system.

**1-11. EQUIPMENT DATA**

*a. 125-GPM Pump and Engine Assy*

Pump, Centrifugal, Fresh  
 Water, 125 GPM, 50 Foot Head  
 Deleted  
 NSN: 4320-00-542-3347 for Model WPSS100  
 Model: Military Model 2-125-50-G  
 (52109 and A52109)

Engine, Gasoline 3 HP

Model: 2A016-2 or 2A016-3  
 Weights and Dimensions

Shipping Weight .....	146 lbs. (66.28 kg.)
Length .....	22 in. (55.88 cm.)
Width .....	18 in. (45.72 cm.)
Height .....	28 in. (71.12 cm.)
Cubage .....	6.4 c ft. (.1792 cu. m.)
Capacities	
Fuel Tank .....	1 gal. (3.785L.)
Crankcase .....	4/5 qt. (0.7568L.)
Air Cleaner .....	1/8 qt. (0.1183L.)

**1-4 Change 8**

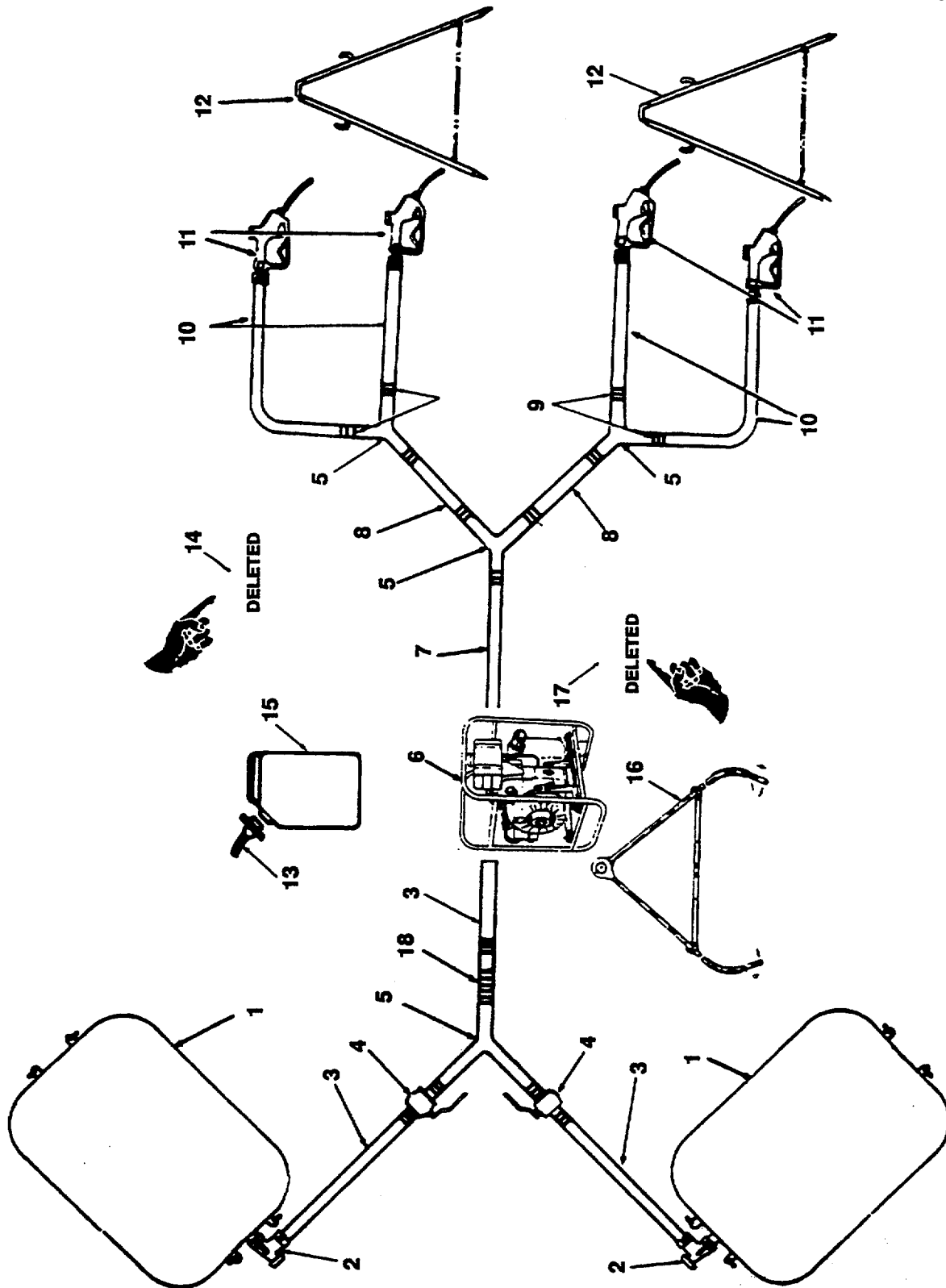

Figure 1-1. Forward Area Water Point Supply System (FAWPSS)

**TM 5-4320-301-13&P**  
**TM 08936A-13&P/1**

NSN 4320-01-247-7127 FOR MODEL 9095-91

Part Number: 5500233000

Engine, Diesel 3.8 HP

Capacities

Fuel Tank .....	0.92 gallon (3.5 liters)
Engine Crankcase.....	0.79 quart (0.75 liter)

Weights and Dimensions

Overall Width .....	32.00 in (81.3 cm)
Overall Length.....	37.25 in (94.6 cm)
Overall Height .....	23.75 in (60.3 cm)
Gross Weight .....	144 lb (65.3 kg)
Shipping Volume .....	16 cubic feet (0.453 cubic meter)

Engine, Diesel 3 HP (Marine Corps Use Only)

Model A52109H

NSN 4320-01-190-0417

Weights and Dimensions

Shipping Weight with Crate.....	350 lbs. (158.76 kg.)
Length .....	22 in. (55.88 cm.)
Width .....	19 in (48.3 c)
Height.....	26 in. (66 cm.)
Cubage.....	6.3 cu ft. (.1764 cu. m.)

Capacity

Fuel Tank .....	1 gal.
Crankcase .....	1.1 qt. sump cap (splash type oil system)
Air Cleaner .....	rating up to 88 cfm

Performance

Pump.....	125 gpm (473.12 Lpm)
-----------	----------------------

*b. 500 Gallon (1893 liter) Water Drum (GFE)*

Overall dimensions and weight (filled)

Length, maximum .....	58 in (1.47 m)
Diameter, maximum .....	55 in (1.40m)
Weight .....	4432 lb (2010 kg)
Cubage.....	67 cu ft (1.89 m <sup>3</sup> )

Weight (empty)

Crated .....	315.0 lb (143 kg) max
Uncrated.....	230.0 lb (104 kg) max

Dimensions (crated)

Length .....	80.5 in (2.04 m)
Width .....	41.5 in (1.05 m)
Height.....	185 in (0.47 m)
Cubage.....	35.8 cu ft(1.01m <sup>3</sup> )

c. *Valve Assys and Y-Connectors*

**NOTE**

The two valves supplied with the FAWPSS have a male and female quick-disconnect cam-locking connector. These connectors were installed at the factory and allow the valves to be quickly installed or removed from the system.

- (1) Valve Assy ..... 2-inch bronze/aluminum type threaded ball valve
- (2) Y-Connector ..... 2-inch bronze/aluminum type quick-disconnect cam-locking

d. *Interconnecting Hose Assy.*

**NOTE**

All hose assys supplied with the FAWPSS are equipped with quick-disconnect, cam-locking connectors. Each hose assy is equipped with a protective cap at one end and a protective plug at the opposite end. A short chain with hook attaches the plugs and caps the hose assys.

- (1) 2-Inch by 10-Foot Suction Hose Assy..... 3 each
- (2) 2-Inch by 10-Foot Discharge Hose Assy ..... 1 each
- (3) Inch by 25-Foot Discharge Hose Assy..... 2 each
- (4) 1 2-Inch by 25-Foot Discharge Hose Assy ..... 4 each

**Section III**

**TECHNICAL PRINCIPLES OF OPERATIONS**

**1-12. DESCRIPTION AND OPERATION.** The FAWPSS system illustrated in this manual is a portable, self contained unit that dispenses potable drinking water to troop units in arid regions. The FAWPSS is operated by a 125GPM centrifugal pump. Six 500gallon water storage and dispensing drums are attached. two at a time. Quick-disconnect couplings connect the drum and balance the system; these drums provide water, by the suction of the 125 GPM pump through hoses, valves, and connecting assys. to four distribution nozzles, where the water is manually discharged. Water may be taken from both 500 gallon drums by opening two sets of valves numbered (2 and 4, figure 11) or you may choose to use only one drum by closing valves (2 and 4, figure 11) on one side of the system. Leaving the remaining valves open will allow use of one drum so that the other may be serviced or repaired. The amount of water discharged through the nozzles can be varied.



## CHAPTER 2 OPERATING INSTRUCTIONS

### Section I DESCRIPTION AND USE OF OPERATOR'S CONTROLS AND INDICATORS

**2-1. GENERAL.** This section contains descriptions of operator controls and indicators for the FAWPSS system. Controls and indicators for the 125 GPM Pump are described in TM 5-2805-257-14 and TM 5-4320-208-12&P for the Model WPSS100 system and in TM 5-4320-309-14 for the Model 9095-91 system.

**2-2. SYSTEM CONTROLS AND INDICATORS.** This section contains descriptions of operator controls and indicators for the FAWPSS system. To ensure that the equipment is ready for operation at all times it must be inspected (as outlined in Section II of this chapter) before operation, and after operation so that defects may be discovered and corrected before they result in serious damage or failure of the system. The necessary preventive maintenance checks and services will be performed before operation. Defects discovered during operation of the system will be noted for future correction, to be made as soon as operation has ceased. Stop operation immediately if a deficiency is noted during operation which would damage the equipment if operation were continued. After operation, preventive maintenance checks and services, (PMCS) will be performed at intervals based on the normal operations of the equipment. Reduce the interval to compensate for abnormal conditions. Report defects or unsatisfactory operating characteristics beyond the scope of the operator to organisational maintenance at the earliest opportunity.

Control or Indicator

Function

125 GPM Pump and Engine Assy

For Model WPSS100 refer to TM 5-2805-257-14 for engine operating controls and TM 5-4320-208- 12&P for 125 GPM water pump operation. For Model 9095-91 refer to TM 5-4320-309-14 for engine operating controls and 125 GPM water pump operation.

500 Gallon Water Drum Assy

Refer to TM I0-8110-202-13&P for operating controls and conditions.

Elbow Coupler Valve Assy

The handwheel is a manual control which is used to open and close the elbow coupler valve assy. Turn the handwheel clockwise to close the elbow coupler valve assy and stop the flow of water. Turn the handwheel counterclockwise to open assy and start flow of water.

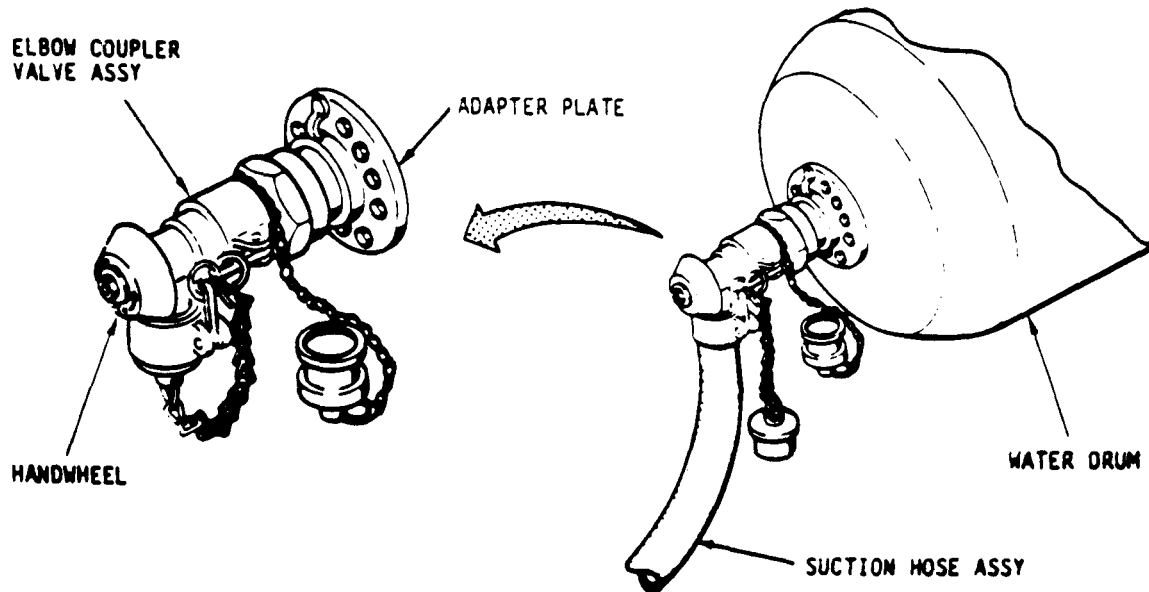



Control or Indicator

Function

2-Inch Valve Assy

The 2-inch valve assy is a manual control used to control the flow of water to the 125 GPM pump and engine assy. The valve assy is open with the control handle (as shown below) allowing water to flow to the 125 GPM pump and engine assy.

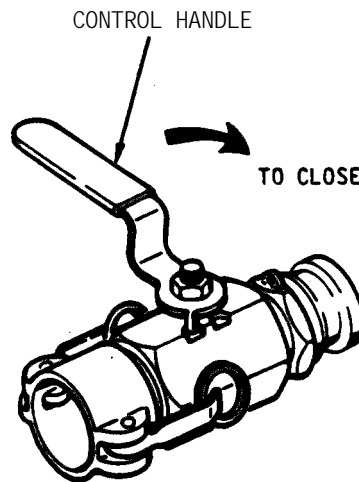

Water Distribution Nozzle

The water distribution nozzle is a manual control used to disperse water. The control handle of the water distribution nozzle is spring loaded. Remove the protection cap from the water distribution nozzle handle, before dispensing water.

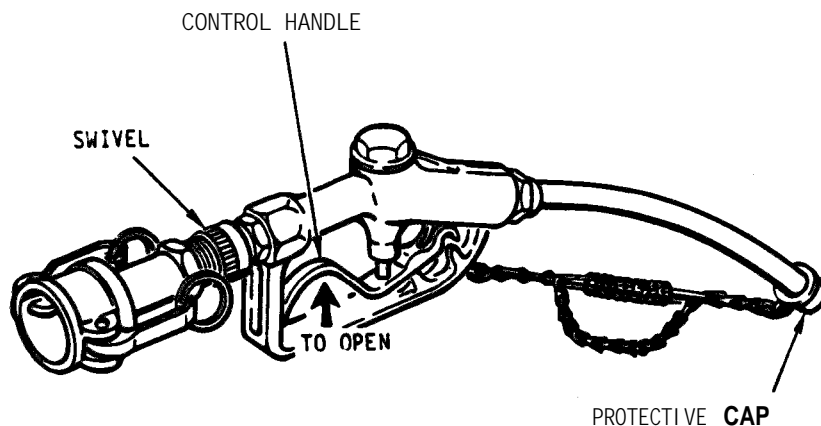

## Section II.

### OPERATOR'S PREVENTIVE MAINTENANCE CHECKS AND SERVICES (PMCS)

**2-3. GENERAL.** Preventive Maintenance Checks and Services (PMCS) means systematic caring, inspecting, and servicing of equipment to keep it in good condition and to prevent breakdowns. As the FAWPSS operator, your mission is to:

- a. Be sure to perform your PMCS each time you operate the FAWPSS. Always do your PMCS in the same order, so it gets to be a habit. Once you've had some practice, you'll quickly spot anything wrong.
- b. Do your BEFORE (B) PMCS just before you operate the FAWPSS. Pay attention to WARNINGS, CAUTIONS, and NOTES.
- c. Do your DURING (D) PMCS while you operate the FAWPSS. During operation means to monitor the FAWPSS and its related components while it is actually being operated. Pay attention to WARNINGS, CAUTIONS, and NOTES.
- d. Do your AFTER (A) PMCS right after operating the FAWPSS. Pay attention to WARNINGS, CAUTIONS, and NOTES.
- e. Do your WEEKLY (W) PMCS once a week.
- f. Do your MONTHLY (M) PMCS once a month.
- g. Use DA Form 2404 (Equipment Inspection and Maintenance Worksheet) to record any faults that you discover before, during, or after operation, unless you can fix them. You DO NOT need to record faults that you fix.
- h. Be prepared to assist unit maintenance in any lubrication procedures. Perform any other services when required by unit maintenance.

### 2-4. PMCS PROCEDURES.

- a. Your Preventive Maintenance Checks and Services, Table 2-1, lists inspections and care required to keep your FAWPSS in good operating condition. It is set up so you can make your BEFORE (B) OPERATION checks as you perform a general examination of the FAWPSS.
- b. The "INTERVAL" column of Table 2-1 tells you when to do a certain check or service.
- c. The "PROCEDURE" column of Table 2-1 tells you how to do required checks and services. Carefully follow these instructions. If you do not have tools, or if the procedure tells you to, notify your supervisor.

### NOTE

Terms "ready/available" and "mission capable" refer to same status: Equipment is on hand and ready to perform its combat missions. (See DA Pam 738-750)

- d. The "NOT FULLY MISSION CAPABLE IF:" column in Table 2-1 tells you when your FAWPSS is nonmission capable and why the FAWPSS cannot be used.
- e. If the FAWPSS does not perform as required, refer to Chapter 3, Section II, Troubleshooting.

f. If anything looks wrong and you can't fix it, write it on your DA Form 2404. IMMEDIATELY report it to your supervisor.

g. When you do your PMCS, you will always need a rag or two. Following are checks that are common to the FAWPSS:

(1) Keep It Clean. Dirt, grease, oil, and debris only get in the way and may cover up a serious problem. Clean as you work and as needed. Use dry cleaning solvent (SD-2) on all metal surfaces. Use soap and water when you clean rubber or plastic material. Upholstery can be cleaned with soap and water and a clean, damp cloth.

(2) Bolts, Nuts, and Screws. Check them all for obvious looseness, missing, bent, or broken condition. You can't try them all with a tool, but look for chipped paint, bare metal, or rust around bolt heads. If you find a bolt, nut, or screw you think is loose, tighten it or report it to your supervisor.

(3) Welds. Look for loose or chipped paint, rust, or gaps where parts are welded together. If you find a bad weld, report it to your supervisor.

(4) Electric Wires and Connectors. Look for cracked, frayed, or broken insulation, bare wires, and loose or broken connectors. Tighten loose connectors. Report any damaged wires to your supervisor.

(5) Hoses and Fluid Lines. Look for wear, damage, and leaks, and make sure clamps and fittings are tight. Wet spots show leaks, but a stain around a fitting or connector can also mean a leak. If a leak comes from a loose fitting or connector, tighten it. If something is broken or worn out, report it to your supervisor.

h. When you check for "operating condition," you look at the component to see if it's serviceable.

**2-4.1 SPECIAL INSTRUCTIONS.** If the equipment must be kept in continuous operation, check and service only those items that can be checked and serviced without disturbing operation. Make complete checks and services when equipment can be shutdown.

**2-4.2 LEAKAGE DEFINITIONS FOR OPERATOR PMCS.** It is necessary for you to know how fluid leakage affects the status of the truck. Following are types/classes of leakage an operator needs to know to be able to determine the status of the truck. Learn these leakage definitions and remember-when in doubt, notify your supervisor.

### CAUTION

When cleaning underhood areas, engine must be COLD (same temperature as outside air). DO NOT point water or steam directly at any electrical connection. DO NOT point water stream directly at radiator fins. DO NOT use high pressure water supply system. Damage to engine, electrical system, and other components may result.

- Equipment operation is allowable with minor leakages (Class I or II). Of course, consideration must be given to fluid capacity in the item/system being checked/inspected. When in doubt, notify your supervisor.
- When operating with Class I or II leaks, continue to check fluid levels as required in your PMCS.
- Class III leaks should be reported immediately to your supervisor.

a. CLASS I - Seepage of fluid (as indicated by wetness or discoloration) not great enough to form drops.

b. CLASSII - Leakage of fluid great enough to form drops but not enough to cause drops to drip from item being checked/inspected.

c. CLASS III-Leakage of fluid great enough to form drops that fall from item being checked/inspected.

2-1. Operator Preventive Maintenance Checks and Services  
 for Forward Area Water Point Supply System

Item No.	inter-val	Location	Procedure	Not Fully Mission Capable
		Item to Check/ Service		
1	Before	HOSE ASSEMBLIES	Check all hose couplings for missing gaskets.	Coupling halves gaskets are missing.
	Before		Check hoses for cuts, cracks, and deterioration.	Hoses are cut, cracked, or deteriorated.
	Before		Check for damaged or missing coupling halves.	Coupling halves are damaged or missing.
2	Before	BALL VALVE ASSEMBLIES	Inspect valve handles for damage.	Valve handles are damaged.
	Before		Check all valves for proper operation.	Valves do not operate properly.
	Before		Inspect valve coupling halves for damage and for missing gaskets.	Valve coupling halves are damaged or gasket is missing
3	Before	NOZZLE ASSEMBLIES	Inspect nozzles for cracks, damage, or missing parts.	Nozzles are cracked, damaged, or has missing parts.
	Before		Check control handle for proper operation.	Control handle does not operate properly.
	Before		Inspect couplings for damage or missing gaskets.	Coupling are damaged or gaskets are missing.
	Before		Check that nozzle swivel fittings operate smoothly.	Swivel fittong is jammed or does not operate smoothly.
4	Before	NOZZLE STAND ASSEMBLIES	Inspect nozzle stands for damage or missing parts.	Nozzle stands are damaged or have missing parts.
5	Before	TOWING & LIFTING YOKES	Inspect towing yokes for damage or missing parts.	Towing yokes are damaged or have missing parts.
6	Before	MISC. FITTINGS	Inspect all fittings for damage or missing gaskets.	Fittings are damaged or gaskets are missing.
7	During	HOSE ASSEMBLIES	Check hose and fittings for leaks.	Hoses or fittings leak.

2-1. Operator Preventive Maintenance Checks and Services  
for Forward Area Water Point Supply System (Cont.)

Item No.	Inter-val	Location	Procedure	Not Fully Mission Capable
		Item to Check/Service		
9	During	NOZZLE ASSEMBLIES	Inspect nozzle for leaks.	Nozzle leaks.
10	During	MISC. FITTINGS	Inspect fittings and coupling halves for leaks.	Fittings or coupling halves.



### Section III. OPERATION UNDER USUAL CONDITIONS

#### 2-5. ASSEMBLY AND PREPARATION FOR USE.

**2-6. GENERAL.** These procedures describe assembly and preparation for use of the FAWPSS. The system is made up of three major components: water storage drums, a 125 GPM pump, and a water distribution system consisting of several distribution stations. Before attempting to assemble or operate your system, become thoroughly familiar with these three elements.

*a.* To position the two 500-gallon water drums use the lifting and towing yoke assy provided with the system in accordance with TM 10-8110-202-13&P.

*b.* The 125 GPM pump and 3-horse power engine comes fully assembled and ready for use after proper servicing has been accomplished. This Information is contained in TM 5-2805-257-14 for the engine on Model WPSS100 and in TM 5-4320-309-14 for the engine on Model 9095-91.

**2-7. INITIAL ADJUSTMENTS.** Inspect the equipment for any damage incurred during shipment. Report any problems to your supervisor.

#### 2-8. ASSEMBLY PROCEDURE

*a.* Selection and Preparation of Assembly Site.

- (1) Select a level, debris free area approximately 30 feet by 120 feet.
- (2) Place the 125 GPM pump in position with the female quick-disconnect facing toward the water drums and male toward site chosen for distribution of water see figure 2-1.

#### CAUTION

Prior to assembly of hoses ensure rigid hoses (suction) only are installed between pump and water drums. If this is not done, damage to hoses and pump can occur.

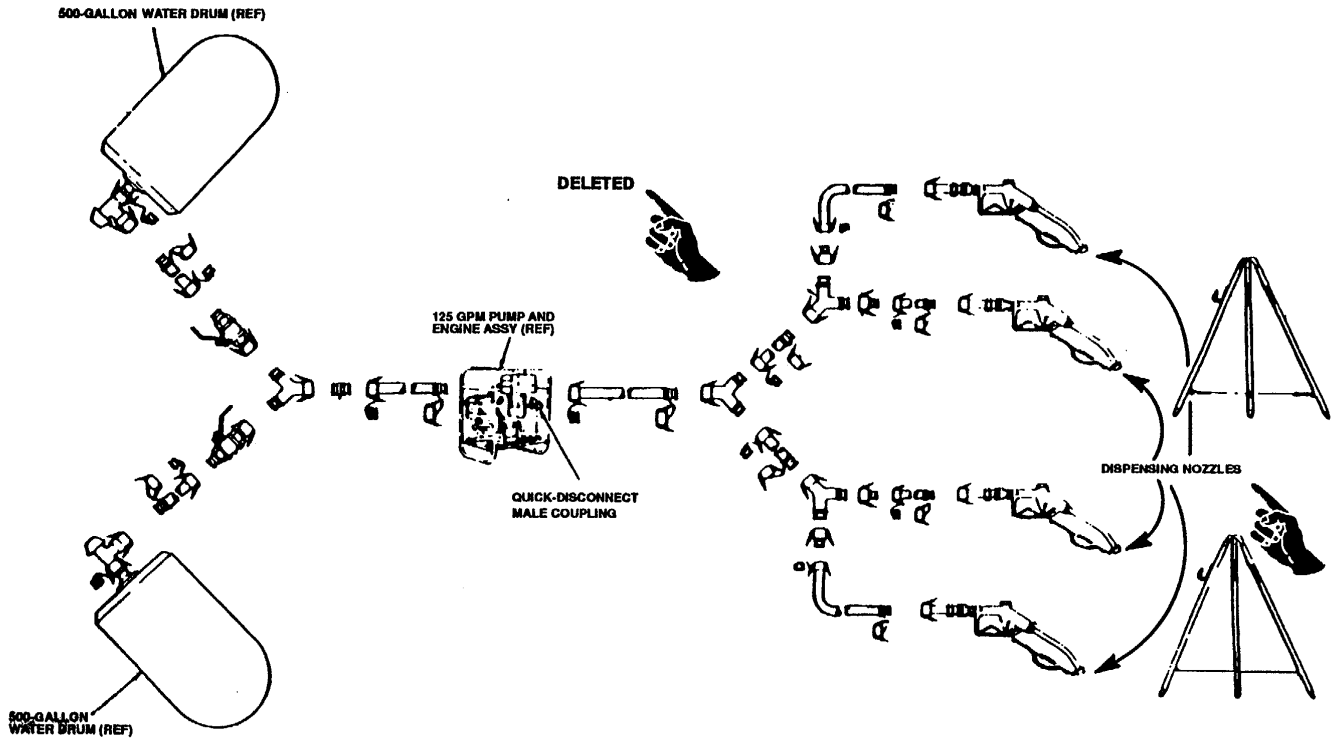
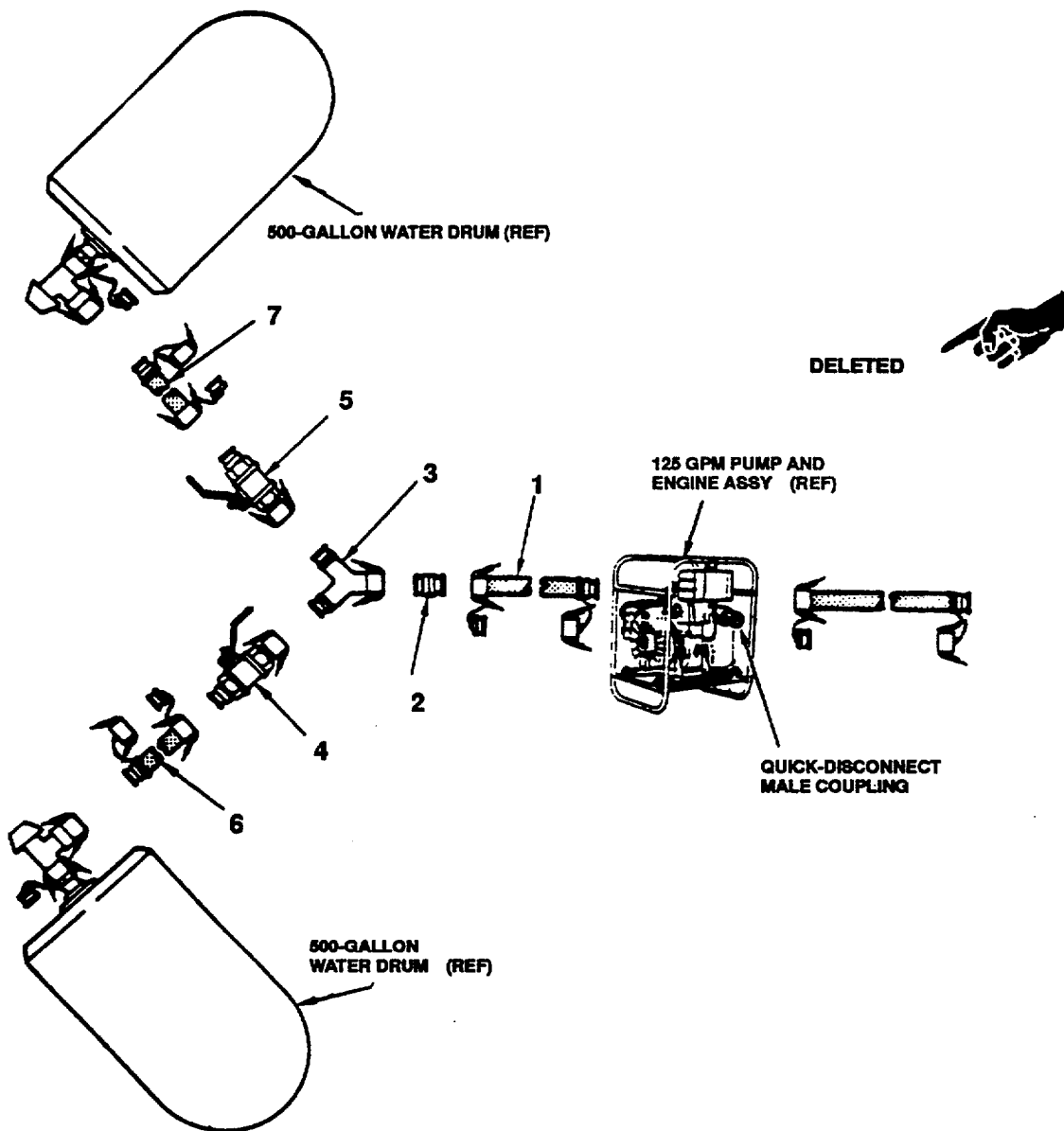

Figure 2-1. Overall View of Forward Area Water Point Supply System (FAWPSS).



**NOTE**

Before connecting hoses or other components ensure that all paper, tape, caps and plugs are removed.



- b. Connect suction hose assy (1) to 125 GPM pump.
- c. Connect double male adapter (2) to suction hose assy (1).
- d. Connect Y-connector (3) to double male adapter (2).
- e. Connect valve assy (5) to Y-connector (3).
- f. Connect suction hose assy (6) to valve assy (4).

- g. Connect suction hose assy (6) to water drum.
- h. Connect valve assy (4) to Y-connector (3).

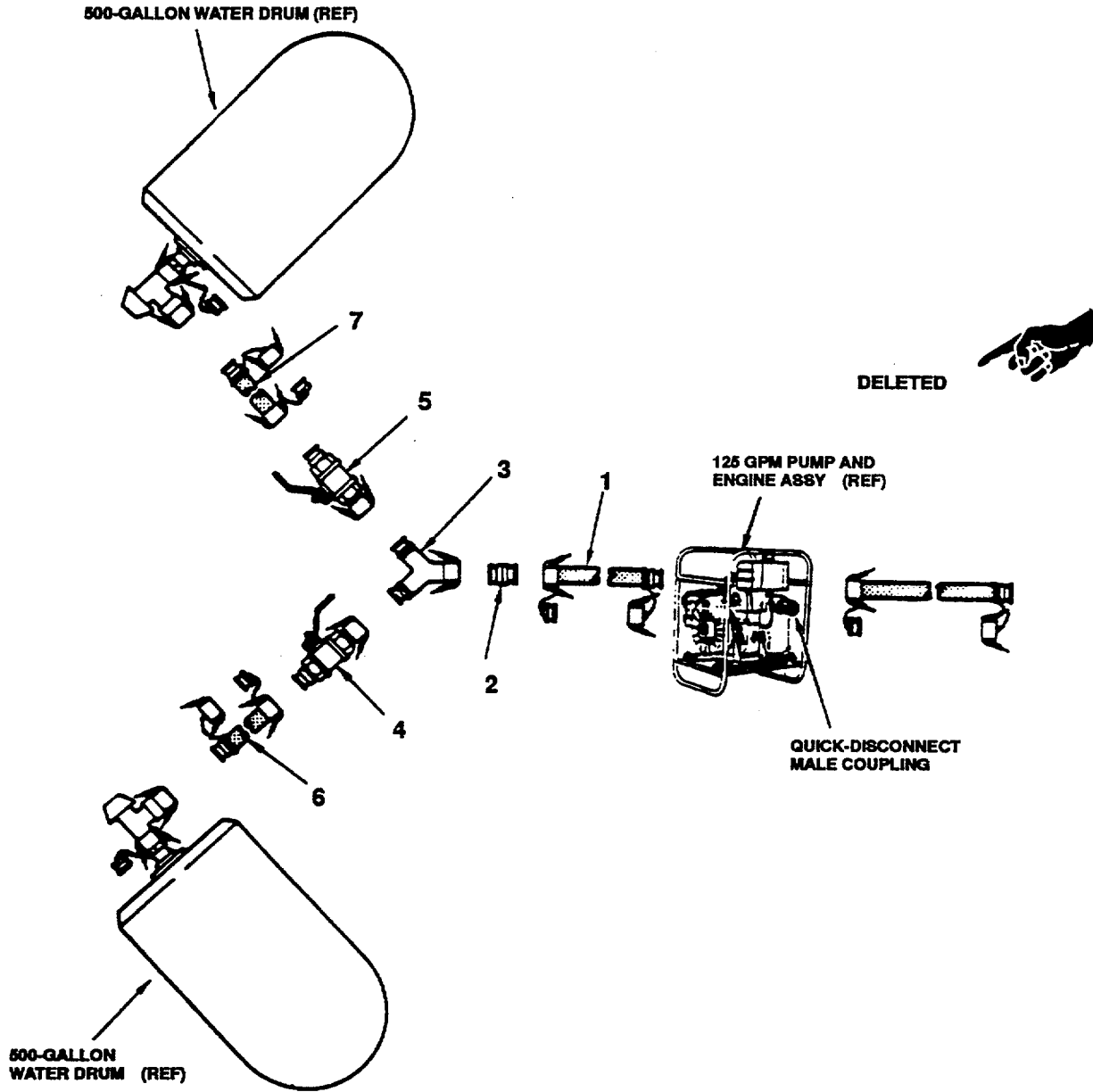

- i. Connect suction hose assy (7) to valve assy (5).
- j. Connect suction hose assy (7) to water drum.

- k. Connect discharge hose assy (1) to male coupling half on 125 GPM pump assy.
- l. Connect discharge hose assy (1) to Y-connector (2).

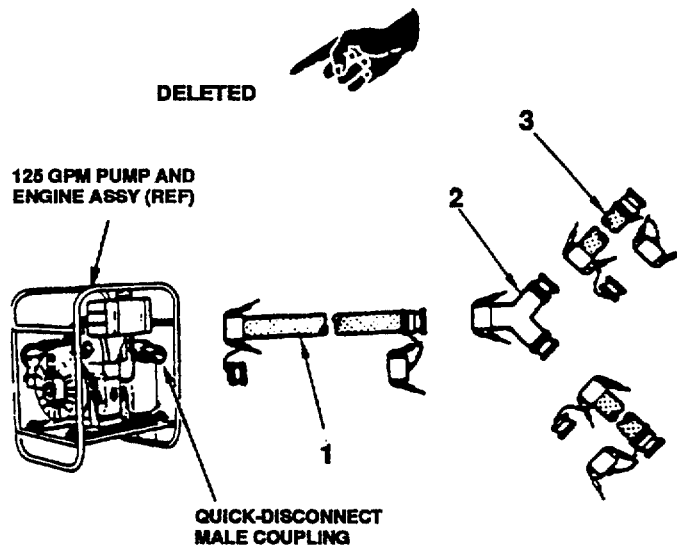

**NOTE**

The following assembly procedures cover one dispensing point. Repeat procedure for the three remaining dispensing points as they are required.

- m. Connect discharge hose assy (3) to Y-connector (2).

TM 5-4320-301-13&P  
TM 08936A-13&P/1

- n. Connect discharge hose assy (3) to Y-connector (4).
- o. Connect female to male reducer (5) to male end of Y-connector (4).
- p. Connect discharge hose assy (6) to reducer (5).
- q. Unfold and position stand assy (8).
- r. Connect nozzle assy (7) to discharge hose assy (6).
- s. Attach nozzle assy (7) to bracket on stand assy (8).
- t. Deleted.

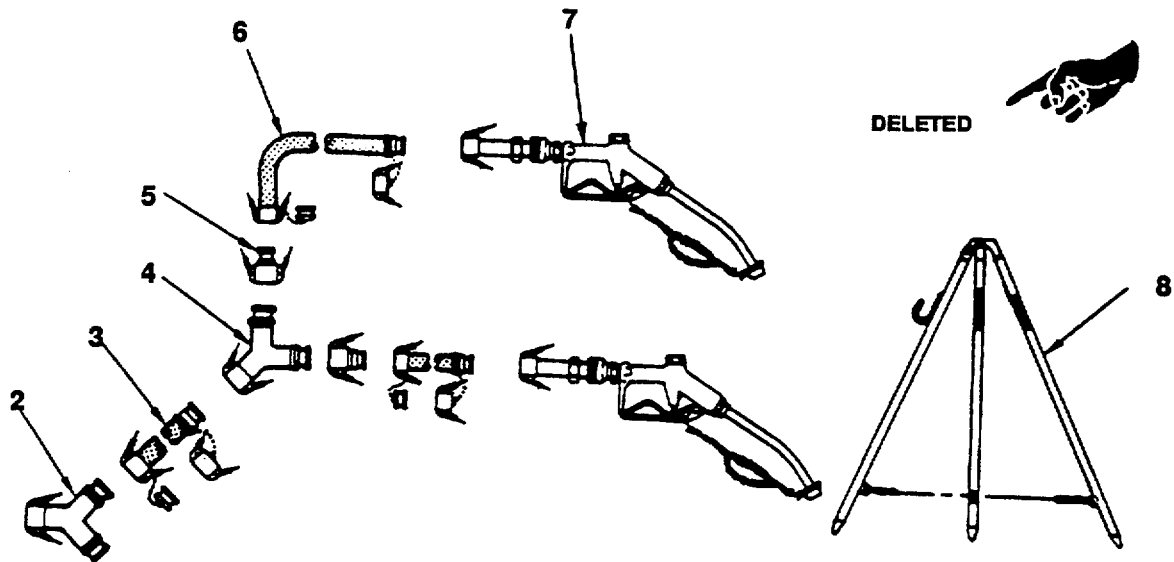

**2-9. WATER SYSTEMS OPERATION.** These procedures describe the operation of the FAWPSS system, in the discharge mode. In the discharge mode, water is discharged from the storage drum by the FAWPSS system.

**FAWPSS Operation.**

- (1) Assure FAWPSS has been properly connected (figure 2-2). Refer to TM 10-8110-202-13&P for detailed water drum setup procedures.
- (2) Turn handwheel clockwise to open the elbow coupler valve assy (2) on each water drum (1).
- (3) Open two 2inch valve assy (4).

**CAUTION**

Do not operate pump unless water is flowing through the system.

- (4) Start 125GPM pump and engine assembly (7). For Model WPSS100 refer to TM 5-2805-257-14. For Model 909591 refer to TM 5-4320-309-14.
- (5) Remove water distribution nozzle from hook on stand assy (13). Pull on spring loaded control handle of water dispensing nozzle (12) to dispense water.
- (6) Release spring loaded control handle of water distribution nozzle (12) to stop flow of water.

**NOTE**

Always replace the protective cap on the nozzle to keep foreign matter out of the nozzle.

- (7) System shutdown procedures are performed in the reverse order of operational procedures.

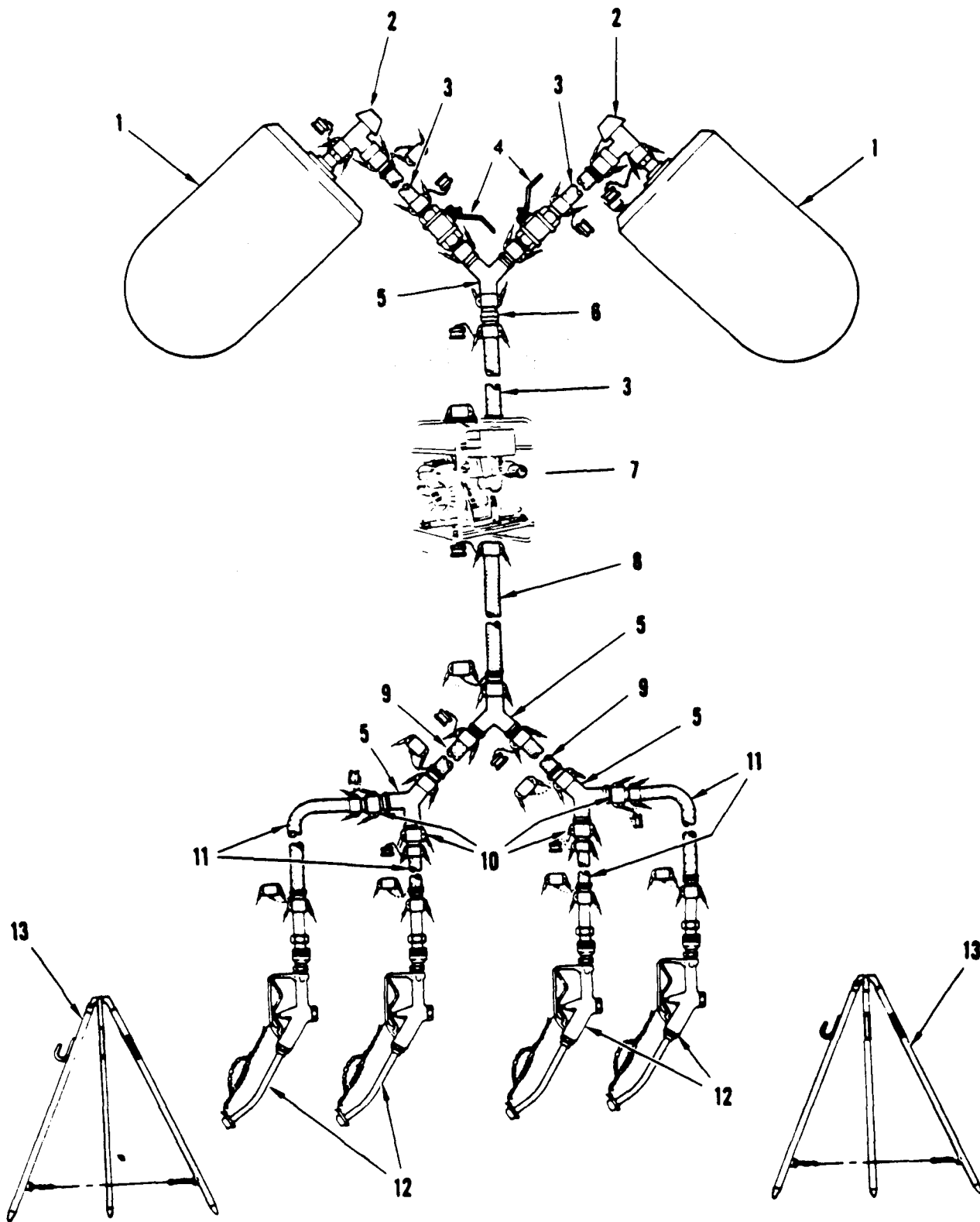

Figure 2-2. FAWPSS Set-up for Dispensing Water

## Section IV OPERATION UNDER UNUSUAL CONDITIONS

**2-10. GENERAL.** This section contains instructions for operation of the FAWPSS in the following conditions: Arctic conditions, extreme heat, salt water areas, high altitudes, strong wind:, and sandy or dusty conditions. For additional information on the drum assemblies, refer to TM 10-8110-202-13&P. For additional information on the Model WPSS100 engine and pump assembly, refer to TM 5-2805-257-14 and TM 5-4320-208-12&P, For additional information on the Model 9095-91 engine and pump assembly, refer to TM 5-4320-309-14.

### *a. OPERATION IN ARCTIC CONDITIONS.*

#### *(1) 125 GPM Pump and Engine Assy.*

- (a) **Keep** engine fuel tank full to prevent condensation. Drain and service fuel filter more frequently than under normal conditions. Refer to TM 5-2805-257-14.
- (b) **Before starting** engine, remove any accumulation of ice or snow from spark plugs and wiring.
- (c) Make sure inlet air temperature shutter on engine is set for winter operation.
- (d) Run engine at **low speed and** allow to warm to operating temperature before applying full load.
- (e) Lubricate engine in accordance with current lubrication order LO 5-2805-257-12.
- (f) Fill pump with warm water to prevent freezing at starting.
- (g) Remove drain plug from pump immediately after each use. For Model WPSS100 refer to TM 5-4320-208-12&P and for Model 9095-91 refer to TM 5-4320-309-14.

#### *(2) 500-Gallon Water Drums and Hose Assys.*

- (a) The 500-gallon water drums must be stored in a heated atmosphere in order to avoid freezing.
- (b) Be careful when handling the hose assys and water drums to **avoid cracking them**. Always wear arctic mittens when handling water dispensing nozzles and other equipment associate! with the FAWPSS.
- (c) Remove snow, sleet, or ice from the 500-gallon water drums before installing the coupler elbow valve assy. Refer to TM10-8110-202-13&P.

#### *(3) Nozzle Distribution Assy.*

- (a) Before attempting to use nozzle, remove any accumulation of ice or snow from it.

**TM 5-4320-301-13&P**

**TM 08936A-13&P/1**

(b) Check for free-movement of nozzle on swivel.

**b. OPERATING IN EXTREME HEAT 135°F (57.5°C)**

**(1) 125-GPM Pump and Engine Assy.**

- (a) Make sure that inlet air temperature shutter is set for summer operation.
- (b) Keep pump clean and free of dust. If pump is operated indoors, allow sufficient room around unit for air circulation and adequate ventilation. Make sure engine exhaust is vented outside.
- (c) Inspect shrouding and cooling fins of engine for dust or foreign matter which may restrict airflow.
- (d) **Lubricate engine in accordance with current lubrication order L0 5-2805-257-12 or TM 5-2805-257-14 for Model WPSS100 and in accordance with TM 5-4320-309-14 for Model 9095-91.**

**(2) 500- Gallon Water Drums and Hose Assys.**

- (a) Keep 500-gallon water drums and hose assys as cool as possible by one of the following methods as applicable to the location
  - (1) Erect a tent or tarpaulin over the 500-gallon water drums but do not block the circulation of air.
  - (2) Place the water drums and hose assys under the shade of trees or cover with leafy branches where possible.
  - (3) Cover the water drums with wet burlap or other fabric, and keep water drums wet when possible.

**(3) Nozzle Distribution Assy.**

- (a) Before attempting to use nozzle, remove any accumulation of dust or foreign substances.
- (b) Check for free movement of nozzle on swivel

**c. OPERATING IN DUSTY OR SANDY AREAS.**

**(1) 125-GPM Pump and Engine Assy**

- (a) **Service air cleaner daily to keep fuel system free from sand and dirt. For Model WPSS100 refer to TM 5-4320-208-12&P and for Model 9095-91 refer to TM 5-4320-309-14.**
- (b) Strain all fuel before adding to fuel tank. Drain and service fuel filter more frequently than under normal conditions.



(c) Clean pump frequently. Wipe it with a cloth dampened in approved cleaning solvent.

(d) Lubricate engine in accordance with current lubrication order LO 5-2805-257-12 or TM 5-2805-257-14 for Model WPSS100 and in accordance with TM 5-4320-309-14 for Model 9095-91.

**(2) 500-Gallon Water Drums and Hose Assys.**

- (a) In strong winds, anchor water drums with rope or stakes. Bank around the sides of the drum with soil to prevent movement.
- (b) Remove any dust from adapter on water drums prior to connecting coupler elbow valve assy.
- (c) Keep all protective caps and plugs installed when equipment is not in use.

**(3) Nozzle Distribution Assy.**

Check for free movement of nozzle on swivel.



## CHAPTER 3 OPERATOR MAINTENANCE INSTRUCTIONS

### Section I LUBRICATION INSTRUCTIONS

**3-1. GENERAL LUBRICATION INSTRUCTIONS.** The 125GPM pump and engine assembly is the only equipment that requires lubrication in the FAWPSS. The pump uses prelubricated, sealed ball bearings that require no lubrication. Lubricate engine in accordance with current lubrication order L0 5-2805-257-12 or TM 5-2805-257-14 for Model WPSS100 and in accordance with TM 5-4320-309-14 for Model 9095-91.

### Section II OPERATOR TROUBLESHOOTING

#### 3-2. GENERAL.

a. This section provides information useful in diagnosing and correcting unsatisfactory operation or failure of the FAWPSS. Each malfunction is followed by a list of probable causes and actions to take to remedy the malfunction. You should perform the tests/inspections and corrective actions in the order listed.

b. This manual cannot list all malfunctions that may occur; nor all tests and corrective actions. Should a failure occur with the engine assembly on Model WPSS100, refer to TM 5-2805-257-14 and to TM 5-4320-208-12&P for the pump assembly. On Model 9095-91, refer to TM 5-4320-309-14 for the pump and engine assembly.

*Table 3-1. Operator Troubleshooting*

---

#### MALFUNCTION

#### TEST OR INSPECTION

#### CORRECTIVE ACTION

---

#### 1. PUMP [125 GPM] FAILS TO PUMP TO RATED CAPACITY.

Step 1. Inspect low engine speed.

Adjust engine speed. For Model WPSS100 refer to TM 5-4320-208-12&P and for Model 9095-91 refer to TM 5-4320-309-14.

Step 2. Inspect pump for sufficient prime.

Reprime pump. For Model WPSS100 refer to TM 5-4320-208-12&P and for Model 9095-91 refer to TM 5-4320-309-14.

Table 3-1. Operator Troubleshooting (Cont'd.)

---

MALFUNCTION
TEST OR INSPECTION
CORRECTIVE ACTION

---

**2. ELBOW COUPLER VALVE ASSY LEAKS.**

Step 1. Inspect for cracked elbow coupler valve assy body.

Replace with a serviceable elbow coupler valve assy TM 10-8110-202-13&P.

Step 2. Inspect for loose elbow coupler valve assy coupling half connections.

Replace coupling half connections. Refer to TM 10-8110-202-13&P.

Step 3. Inspect for damaged or missing gasket.

Replace with a serviceable gasket. Refer to TM 10-8110-202-13&P.

**3. 2-INCH VALVE ASSY LEAKS.**

Step 1. Inspect female coupler for damaged or missing gasket.

Replace with serviceable gasket.

Step 2. Inspect valve body for leaks and cracks.

Replace with serviceable 2-inch valve assy.

Step 3. Inspect valve body for improper threading or cross-threading.

Replace with serviceable 2-inch valve assy.

**4. Y-CONNECTOR LEAKS.**

Step 1. Inspect for cracks or dents.

Replace with serviceable Y-connector.

Table 3-1. Operator Troubleshooting (Cont'd.)

<b>MALFUNCTION</b>	<b>TEST OR INSPECTION</b>	<b>CORRECTIVE ACTION</b>
<b>5. WATER DISTRIBUTION NOZZLE LEAKS.</b>		
	Step 1. Inspect for damaged or missing gaskets in female coupler.	Replace with serviceable gasket
	Step 2. Inspect for loose or damaged parts.	Replace with serviceable water distribution nozzle assy.
<b>6. HOSE ASSY LEAKS.</b>		
	Step 1. Inspect hose for cuts, cracks, or punctures.	Replace defective hose assy.
	Step 2. Inspect for damaged or missing coupling half gaskets.	Replace with serviceable coupling half gaskets.
<b>7. DELETED.</b>		

**Section III**  
**OPERATOR MAINTENANCE PROCEDURES**

**3-3. INTRODUCTION.** Operator maintenance consists of daily inspections when the FAWPSS system is set up for use, replacement of water hoses and hose fittings. Replacement of defective units or components is beyond the scope of operator maintenance and requires the services of organizational maintenance.

### Section III OPERATOR MAINTENANCE PROCEDURES

#### 3-4. NOZZLE STAND ASSY INSPECT/REPLACE.

##### REMOVAL

Remove stand assy from system by folding up.

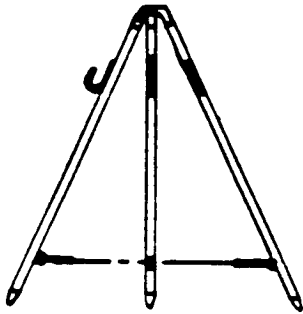

##### INSPECT AND CLEANING

##### WARNING

Dry-cleaning solvent, P-D-680, used to clean parts is potentially dangerous to personnel and property. Avoid inhalation of fumes and repeated or prolonged skin exposure. Wash exposed skin thoroughly with soap and water. Use in well ventilated area away from open flame or excessive heat. Flash point is 100°F (38°C).

- a. Wash all parts in cleaning solvent P-D-680 to remove all dirt and foreign matter. Dry with clean lint free cloth.
- b. Inspect nozzle stand assy in accordance with PMCS.

### Section III OPERATOR MAINTENANCE PROCEDURES (Cont'd.)

#### 3-4. NOZZLE STAND ASSY INSPECT/REPLACE. (Cont'd.)

c. Using proper tools, straighten any bent legs or brackets. Weld any minor cracks or breaks that were detected during inspection. Replace any leg or bracket that is damaged beyond repair.

d. If either chain is damaged, cut a new one approximately 10-inches in length from bulk chain (P/N RRC-271).

e. Replace any remaining parts that are damaged or defective.

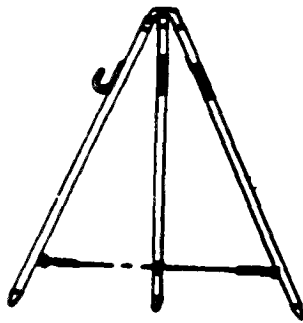

#### INSTALLATION

Install serviceable stand assy into system.

### Section III OPERATOR MAINTENANCE PROCEDURES (Cont'd.)

#### 3-5. HOSE ASSYS, INSPECT/REPLACE.

##### REMOVAL

- a. Removal hose assy from FAWPSS system by disconnecting male and female coupling halves.

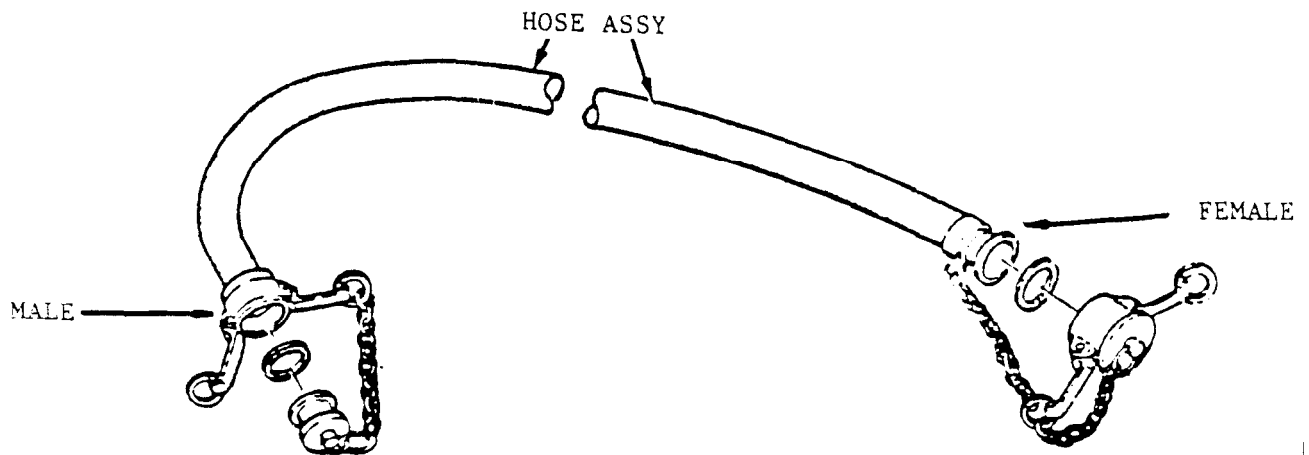

##### INSPECT AND CLEANING

- a. Wash the hose and couplings in a mild soap and water solution. Rinse in clean water and dry with a clean lint free cloth.
- b. Inspect hose and coupling assys in accordance with PMCS.

##### INSTALLATION

Install serviceable hose assy.



### Section III

#### OPERATOR MAINTENANCE PROCEDURES (Cont'd.)

##### 3-6 Towing and Lifting Yoke.

###### INSPECT AND CLEANING

###### WARNING

Drycleaning solvent, PD-680, used to clean parts is potentially dangerous to personnel and property. Use in well ventilated area as the fumes are dangerous if inhaled. Avoid repeated and prolonged skin contact. Do not use near open flame or excessive heat. Flash point of solvent is 100°F-138°F(38°C-59°C).

- Clean the towing and lifting yoke with drycleaning solvent, (item 4 App. D), to remove any foreign matter.
- Inspect the connecting legs and upper legs for breaks cracks, or bends.
- Inspect the chains, pine and key rings for broken or missing parts.
- Inspect the female and male braces for bends, cracks, and breaks.

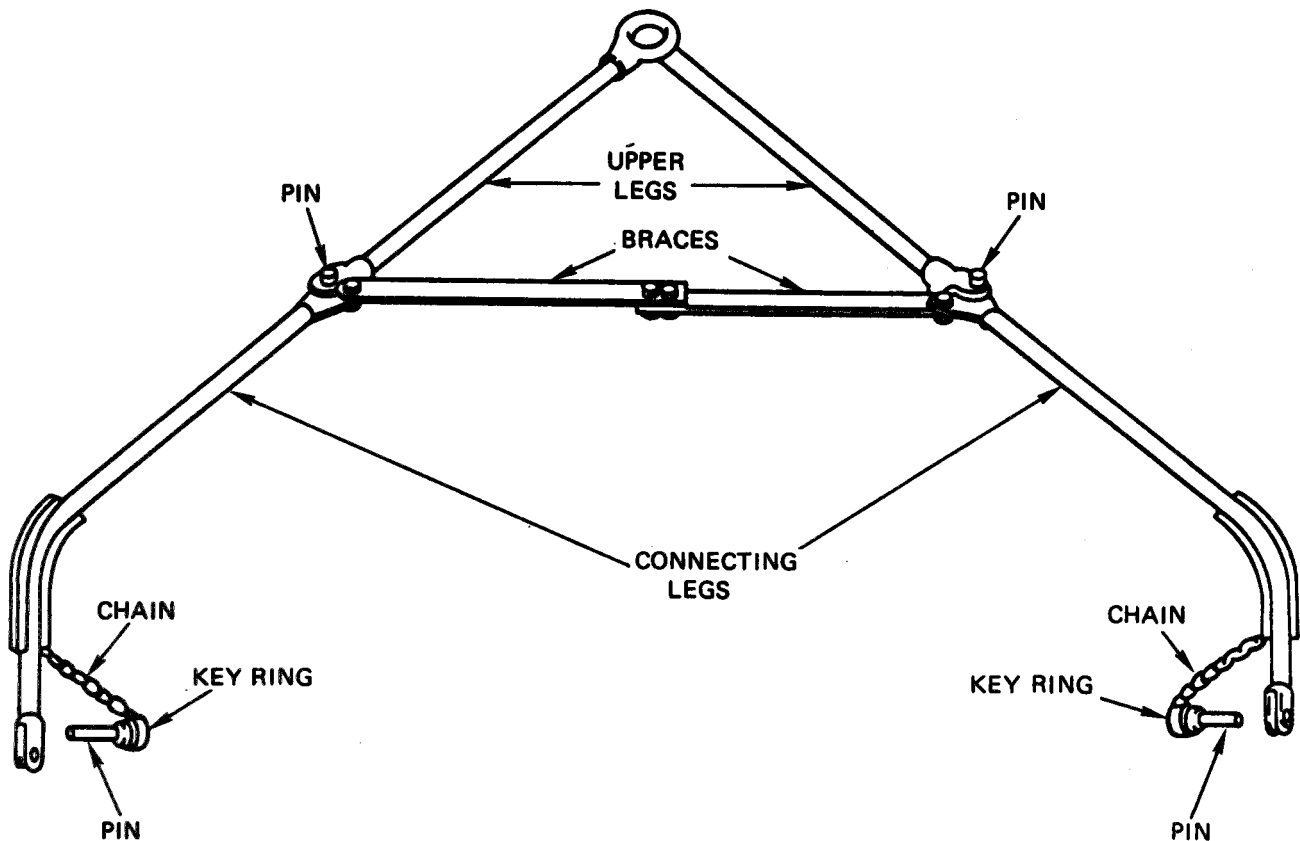

###### REPLACEMENT

Replace the entire towing and lifting assembly, as necessary.



## CHAPTER 4 ORGANIZATIONAL MAINTENANCE, INSTRUCTIONS

### Section I SERVICE UPON RECEIPT

#### 4-1. UNCRATING AND PREPARATION FOR USE .

*a. Uncrating Equipment.* The FAWPSS is shipped in one wooden crate and contains all components of the FAWPSS except the 500 gallon water drum assys. Filled water drums weigh 3,767 pounds and require a lifting device for placement. The FAWPSS (excluding water drums) crated weight is 590 pound and requires a lifting device for removal from transport vehicle.



Use care when removing hoses to avoid puncturing hoses with sharp objects such as nails.

- (1) Select a level, debris free area for setting up the FAWPSS. In an operational setting the FAWPSS requires an area approximately 30 feet by 120 feet.
- (2) Remove top of wooden shipping crate (figure 4-1). An equipment shipping list is supplied with each system. Remove equipment shipping bags from shipping container one at a time.
- (3) Inspect the equipment for damage incurred during shipment. If the equipment has been damaged, report the damage on DD Form 6, Packaging improvement Report.
- (4) Check the equipment against the packing slip to see if the shipment is complete. Report all discrepancies in accordance with the instructions of DA PAM 738-750.
- (5) Check to see whether the equipment has been modified.

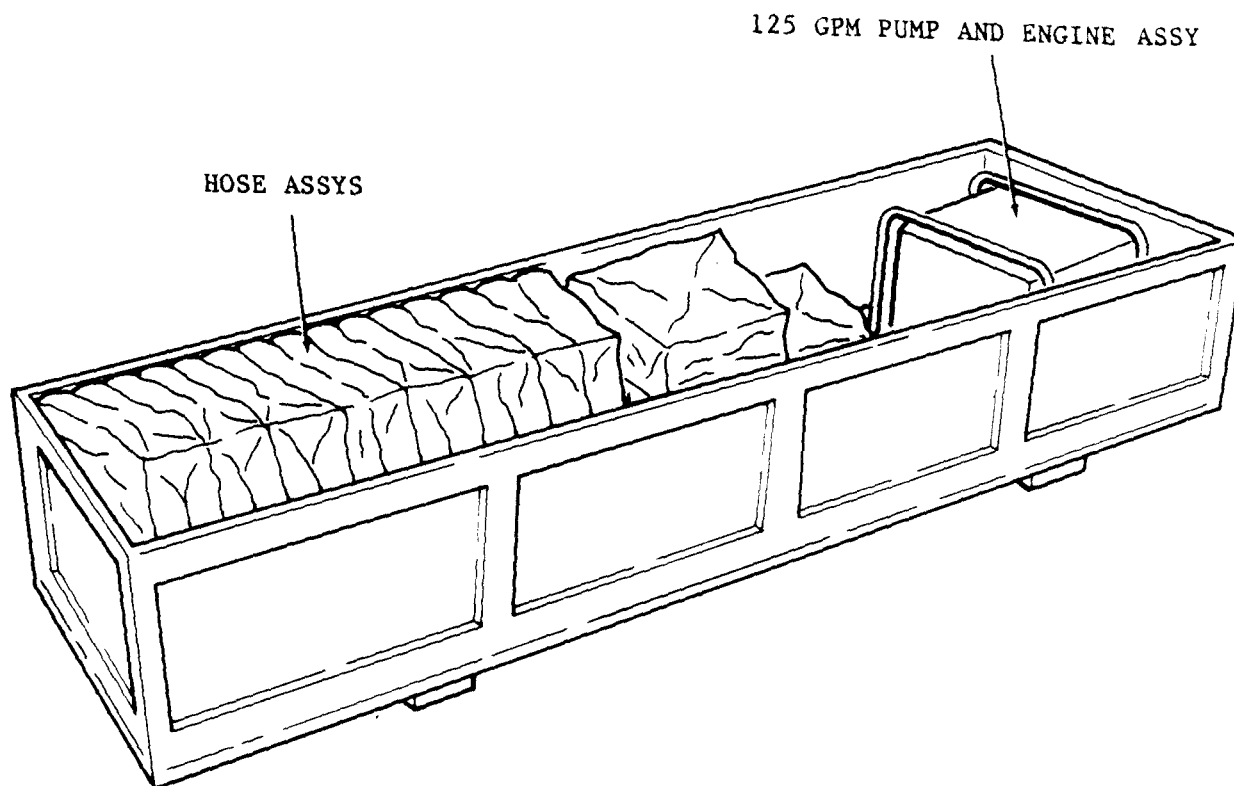

Figure 4-1. FAWPSS Shipping Crate

b. 125 GPM Pump Assy.

- (1) Remove top of shipping crate.
- (2) Remove 125 GPM pump assy from shipping crate.
- (3) Remove overpack kit from shipping crate.
- (4) Check equipment in overpack kit against the packing slip to see if the shipment is complete. Report all discrepancies in accordance with instructions contained in PA PAM 738-750.

c. Hoses

- (1) Carefully remove top of shipping crate to avoid possibility of nails puncturing hose assys.
- (2) Remove required number of hoses from shipping crate.
- (3) Check hose assys against packing slip to insure correct quantity was shipped. Report all discrepancies in accordance with instructions contained in PA PAM 738-750.

d. Towing and Lifting Yoke

- (1) Remove towing and lifting yoke (figure 4-2) from crate.

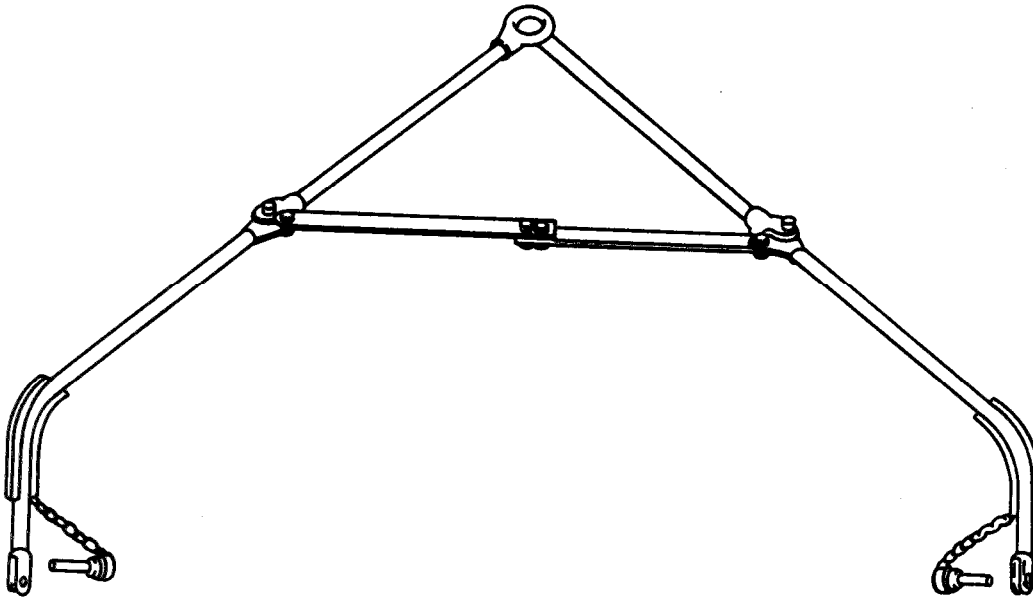

Figure 4-2 Towing and Lifting Yoke

- (2) Remove protective tape or paper from towing and lifting yoke.

e. Kits and Valves Connectors Adapters Nozzles Fittings and Miscellaneous Items. Various kits, miscellaneous parts and equipment are contained in the FAWPS systems.

- (1) **General.** All equipment is preserved, packaged, and crated to meet military requirements. Each kit is shipped with all attachments and equipment necessary for normal operation.
- (2) **Unloading Instructions.** You may lift crated equipment by using a fork lift, crane, or other lifting device capable of lifting 600 pounds safely. If a crane is used, arrange slings under packing crate carefully to ensure crate will not tip. If a fork lift is used, slide fork blades directly under crate between skid blocks.

- (3) **Uncrating.** Carefully uncrate equipment, being sure not to damage components. If the equipment is to be recreated, exercise care to prevent damage to crating material.
- (4) **Unpacking.** Unpack all small components packaged and stored around the larger components. These components can easily be lifted and removed from the packing skid by two workmen.

**NOTE**

Be sure all components are accounted for. Check all packaging material for loose parts before discarding.

- (5) **Servicing.** Remove all protective compounds and covering such as waxed paper, waterproof tape, and barrier material and tape. Using dry wiping cloths, remove all preservatives and greases from unpainted, threaded, or exposed surfaces.
- (6) **Inspection.**
  - (a) Unwrap and examine separately wrapped items to ensure they are in serviceable condition.
  - (b) Visually inspect all components for damage. Check for dents, cracks, broken parts, and loose or kinked connections. Report damaged items on DD Form 6, Packaging Improvement Report.
  - (c) Check bill of lading to ensure that all parts have been supplied. Report all discrepancies in accordance with instructions contained in PA PAM 738750.

**4-2. PREPARATION FOR USE.** Prepare the equipment contained in the FAWPS systems for use as follows.

**NOTE**

Disregard instructions for equipment not contained in your particular equipment configuration. Refer to Appendix F.

- a. **125 GPM Pump Assy.** The 125 GPM pump assy consists of a 3-horsepower engine and a 125 GPM pump.
  - (1) Prepare engine for operation in accordance with instructions in TM 5-2805-257-14 on Model WPSS100 systems and in accordance with TM 5-4320-309-14 for Model 9095-91 systems.
  - (2) Prepare pump for operation in accordance with instructions in TM 5-2805-257-14 On Model WPSS100 systems and in accordance with TM 5-4320-309-14 for Model 9095-91 systems.
- b. **500Gallon Water Drums.** Prepare the 500gallon water drums for use in accordance with instructions continued in TM 10-8110-202-13&P.
- c. **Kit, Valves, and Hose Assys.** All kits, valves and hose assys are ready for use following uncrating. Do not remove the protective plugs and caps until installation. Ensure all valve assys are closed prior to installation in the system

**4-4 Change 8**

**4-2.1 MOVEMENT OF FILLED DRUM BY CARGO TRUCK.** A filled drum maybe moved short distances, at a speed not to exceed 10 mph (16km/hr), by towing with the towing and lifting yoke as shown in figure 4-3.

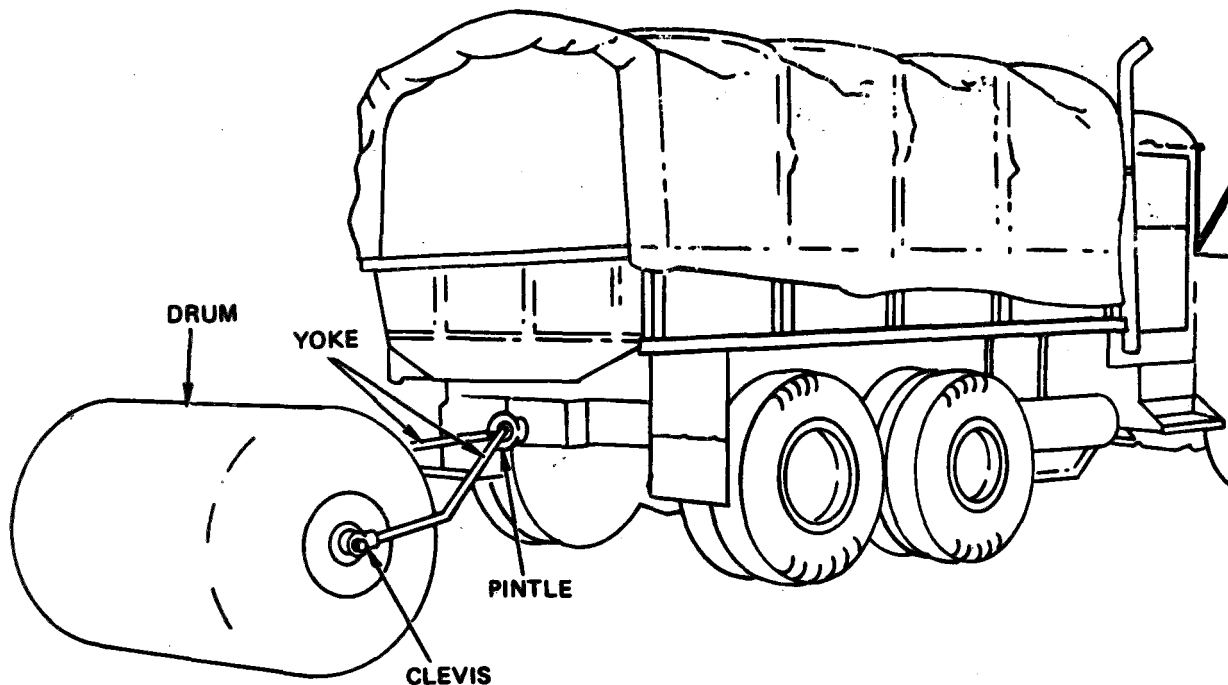

Figure 4-3 Drum attached to cargo truck for towing

- a. Unfold the towing and lifting yoke and connect the two braces.
- b. Install the screws in the braces
- c. Place the shackles in the slots in the end of each connecting leg and install each quick release pin in each connecting leg.
- d. Connect the towing and lifting yoke to the cargo truck pintle hook.
- e. When the drum has been towed to the new location, remove the towing and lifting yoke as follows:
  - (1) Disconnect towing and lifting yoke from the cargo truck pintle hook.
  - (2) Remove the quick release pin from each connecting leg and pull the shackles from the slots.
  - (3) Remove the screws from the braces.
  - (4) Separate the two braces and fold the towing and lifting yoke.

**Section II**  
**REPAIR PARTS, SPECIAL TOOLS, TMDE, AND SUPPORT EQUIPMENT**

**4-3. COMMON TOOLS AND EQUIPMENT.** Refer to the Modified Table of Organization and Equipment (MTOE) applicable to your unit.

**4-4. SPECIAL TOOLS, TMDE, AND SUPPORT EQUIPMENT.** No special tools, TMDE, or support equipment are required for the FAWPS system.

**4-5. REPAIR PARTS.** Repair parts are listed in Appendix C of this manual

**Section III**  
**UNIT PREVENTIVE MAINTENANCE CHECKS AND SERVICES**

**4-6. INTRODUCTION**

a. Systematic, periodic, Preventive Maintenance Checks and Services (PMCS) are essential to ensure that the FAWPSS is ready for operation at all times. The purpose of a maintenance program is to discover and correct defects and deficiencies before they can cause serious damage or complete failure of the equipment. Any effective preventive maintenance program must begin with the training of operators to report all unusual conditions noted during daily checks or actual operation to unit maintenance. AU defects and deficiencies discovered during maintenance inspections must be recorded, together with corrective action taken, on DA Form 2404 (Equipment Inspection and Maintenance Worksheet).

b. A schedule for unit preventive maintenance inspection and service should be established immediately after installation of the FWAPSS. A quarterly interval, equal to three calendar months or 250 hours of operation (whichever occurs first) is recommended for usual operating conditions. When operating under unusual conditions, such as a very dusty or sandy environment, it may be necessary to reduce the interval to monthly or even less if conditions are extreme.

**4-7. UNIT PMCS.** The FAWPSS has no system unit PMCS. However, the pump and engine assembly and collapsible storage drums do have unit PMCS. Refer to the applicable technical manual for these items for proper unit PMCS procedures and perform those procedures.

**Pages 4-7 and 4-8 have been deleted.**

**4-6 Change 8**



## **Section IV**

### **ORGANIZATIONAL TROUBLESHOOTING PROCEDURES**

**4-8. GENERAL.** This section contains troubleshooting information for locating and correcting most of the operating troubles which may develop in your FAWPSS. The troubleshooting procedures are listed in table 4-2. The table lists common malfunctions which you may find during operation or maintenance of the FAWPSS systems or its components. You should perform the tests/inspections and corrective actions in the order listed. Each malfunction for an individual component, unit, or system is followed by a list of tests or inspections which will help you determine actions to take.

**4-9. TROUBLESHOOTING PROCEDURES.** The symptom index lists the common malfunctions which you may find during the operation or maintenance of the FAWPSS system. Use the symptom index for quick access to the troubleshooting procedures. This manual cannot list all possible malfunctions that may occur, nor all tests or inspections and corrective actions. If a malfunction is not listed (except where malfunction and cause are obvious) or is not corrected by listed corrective action, notify your supervisor.

*Table 4-2 Troubleshooting*

---

<b>MALFUNCTION</b>
<b>TESTS OR INSPECTION</b>
<b>CORRECTIVE ACTION</b>

---

1. For troubleshooting the gasoline engine (Army), refer to TM 5-2805-257-14 on Model WPSS100 and to TM 5-4320-309-14 for Model 9095-91. Refer to General Support Maintenance for Engine, 3HP, on diesel engine (Marines).
2. For troubleshooting the pump, refer to TM 5-4320-208-12&P on Model WPSS100 and to TM 5-4320-309-14 for Model 9095-91.
3. Refer to TM 10-8110-202-13&P for troubleshooting the water drum assy.
4. 2-Inch Valve Assy Leaks.

Step 1. Inspect female quick-disconnect for damaged or missing gasket.

Replace with serviceable gasket.

5. Y-Connector leaks.

Step 1. Insert female quick-disconnect for damaged or missing gasket.

Replace with serviceable gasket.

Table 4-2. Troubleshooting (Cont'd.)

---

<b>MALFUNCTION</b>	<b>TEST OR INSPECTION</b>	<b>CORRECTIVE ACTION</b>
<b>6. HOSE LEAKS.</b>		
	Step 1. Aspect for cut or cracked hose.	
		Replace or repair hose assy.
<b>7. HOSE ASSY COUPLING HALVES LEAK</b>		
	Step 1. Inspect for damaged or mining coupling half gasket.	
		Install serviceable coupling half gasket.
	Step 2. Inspect for cracked coupling half.	
		Install a serviceable coupling half.
<b>8. DELETED.</b>		

---

## Section V ORGANIZATIONAL MAINTENANCE PROCEDURES

### 4-10. 2-INCH VALVE ASSY, REPLACEMENT

#### REMOVAL

- a. Mount valve body (2) in vice with protective pads.
- b. Using pipe wrench remove female (1) and Male (3) couplings.
- c. Remove nut (5) from shaft (6) and disengage control handle (4).

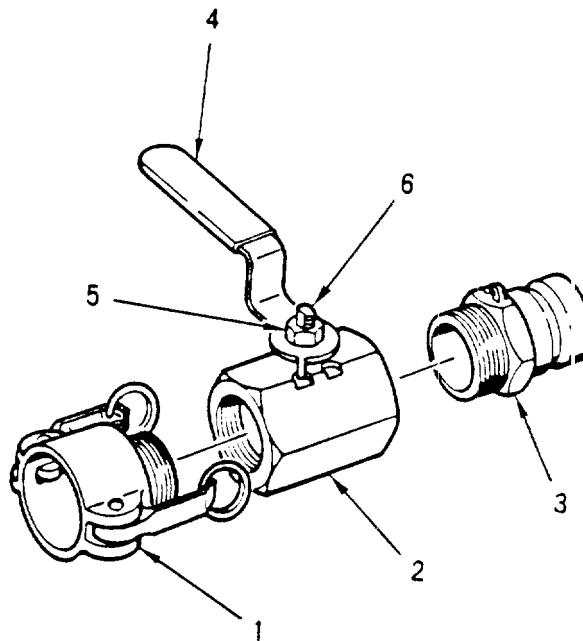

#### INSPECT AND CLEANING

- a. Remove all tape residue from valve body and couplings.
- b. Wash all parts in mild soap and water solution and dry with clean lint free cloth.
- c. Inspect for damaged body (2), and control handle (4).
- d. Replace valve body (2) or handle (4) if damage is found.
- e. Inspect couplings (1 and 3) for cracks, burns or damaged surface.
- f. Replace couplings (1 and 3) if damage is found.

## Section V ORGANIZATIONAL MAINTENANCE PROCEDURES (Cont'd.)

### 4-10. 2-INCH VALVE ASSY REPLACEMENT (Cont'd.)

#### INSTALLATION

- a. Wrap threads of couplings (1 and 3) with one layer of teflon tape ST410.
- b. Install couplings (1 and 3) in valve body (2) and tighten with pipe wrench until snug against body.
- c. Install handle on shaft (6) with nut (5) and tighten until snug.
- d. Return valve to service.

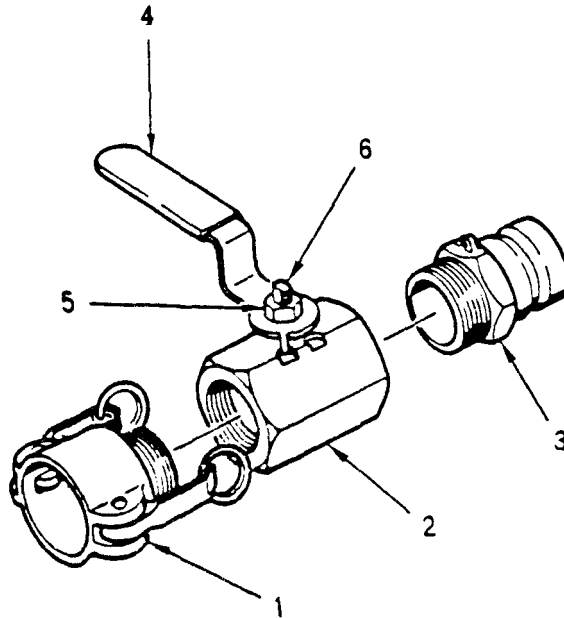

**Section V**  
**ORGANIZATIONAL MAINTENANCE PROCEDURES (Cont'd.)**

4-11. NOZZLE DISTRIBUTION ASSY, REPLACEMENT. (Cont'd.)

**REMOVAL**

- a. Remove dust plug (9) and retaining ring (10) from female quick-disconnect reducer (2).
- b. Remove damaged female quick-disconnect reducer (2) from swivel (3).
- c. Remove all tape residue from swivel (3).
- d. Remove damaged swivel (3) from nozzle body (4), using wrench.
- e. Remove all tape residue from nozzle body (4) and threaded end of female quick-disconnect reducer (2).
- f. Unscrew female quick-disconnect and reducer (2) from swivel (3).

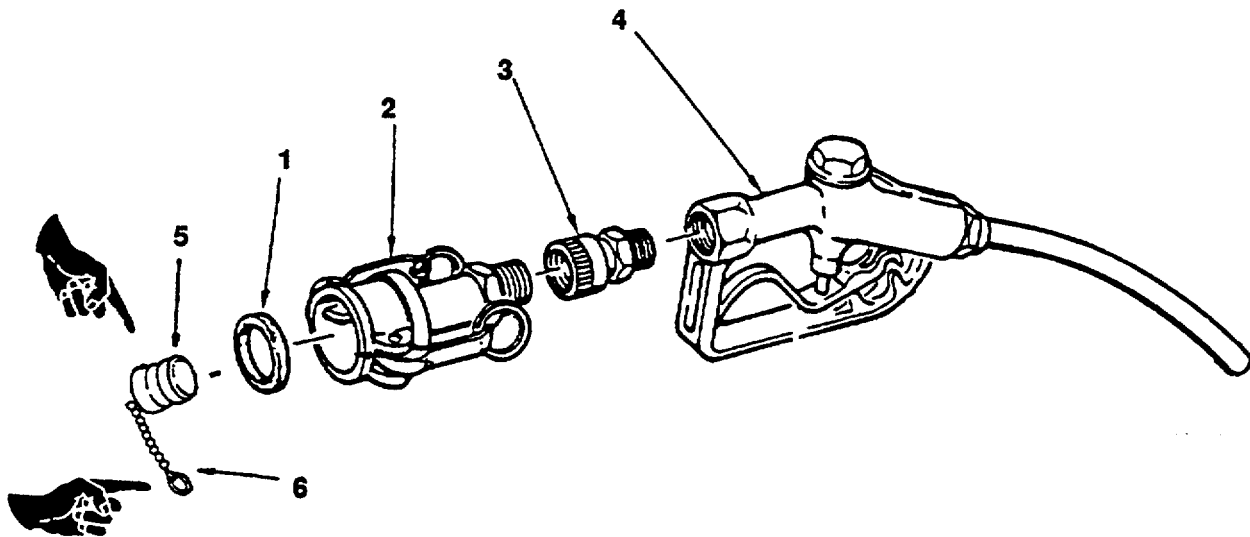

**INSPECTION AND CLEANING**

- a. Wash the valve assy in a mild soap and water solution. Rinse in clean water and dry with a clean lint-free cloth.
- b. Inspect for missing gasket (1).
- c. Inspect for missing protective cap (5) chain (6) or spring (7)
- d. Inspect control handle (8), female quick-disconnect reducer (2). or swivel (3).

Section V  
ORGANIZATIONAL MAINTENANCE PROCEDURES (Cont'd.)

4-11. NOZZLE DISTRIBUTION ASSY, REPLACEMENT (Cont'd.)

**INSTALLIION**

- a. If nozzle body (4) is cracked or damaged replace water distribution nozzle.
- b. Wrap threaded end of swivel (3) with one layer of teflon tape ST410.
- c. Wrap threaded end of female quick-disconnect reducer (2) with one layer of teflon tape ST410.
- d. Install female quick-disconnect and reducer (2) in swivel (3).
- e. Install swivel (3) in threaded end of nozzle body (4).
- f. Attach dust plug (5), chain and retaining ring (6) to female quick-disconnect reducer (2).

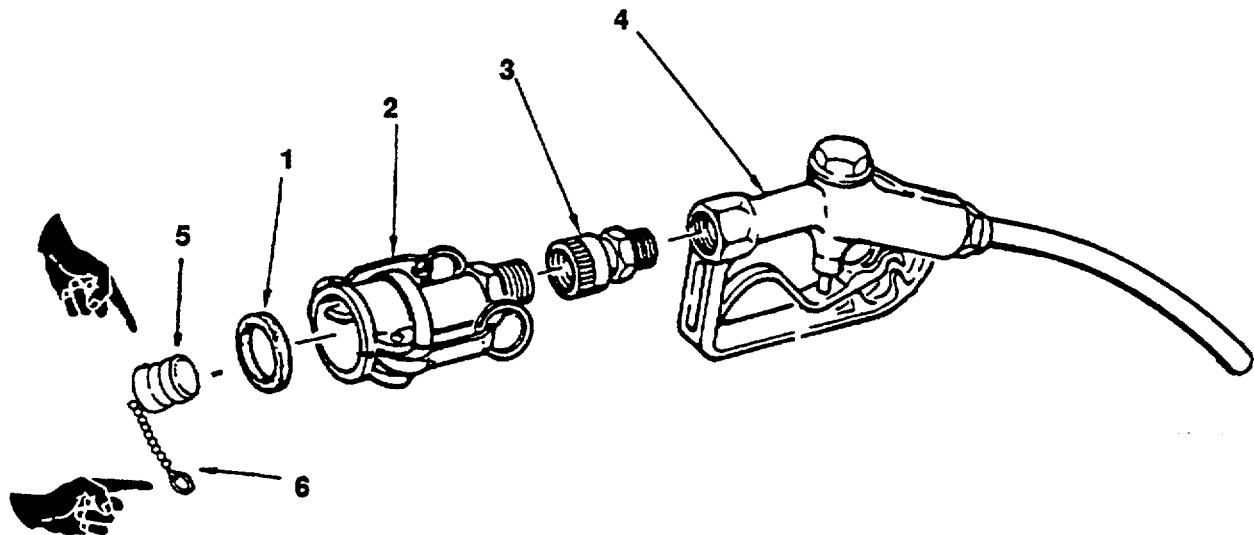

Section V  
ORGANIZATIONAL MAINTENANCE PROCEDURES (Cont'd.)

4-12. STAND ASSY, REPAIR

REMOVAL

- a. Remove stand assy from FAWPSS by folding up and replacing with serviceable stand. Ensure cap is on end of nozzle when hanging on new stand

NOTE

Only disassemble the parts of stand that require repair or replacement.

- b. With a common screwdriver pry open three s-hooks (1) on chain ends and remove from sash chains (2) and legs (3/5).
- c. Remove two cotter pins (6) from clevis pins (4) in legs (3/5).
- d. Remove clevis pins (4) and separate clevis legs (5) from pivot leg (3).

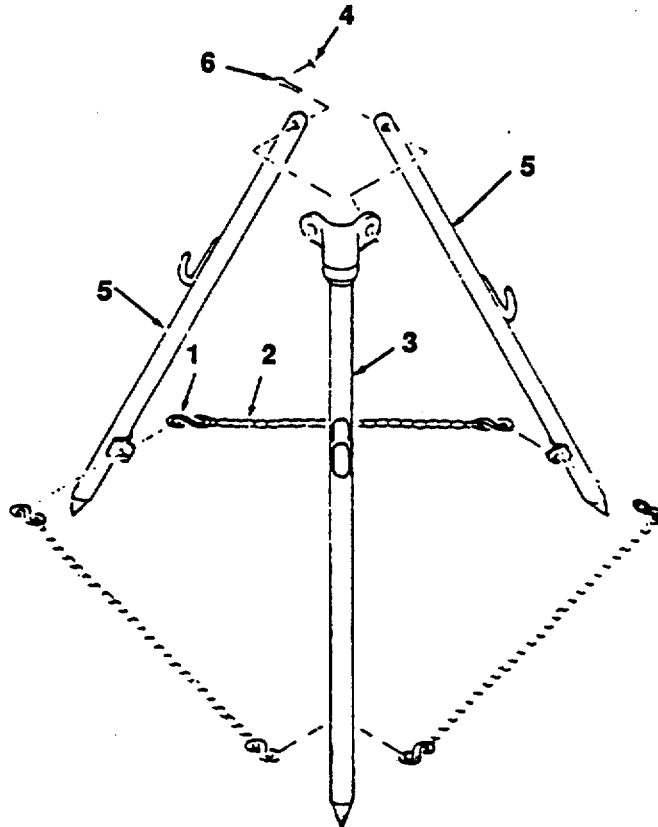

**Section V**  
**ORGANIZATIONAL MAINTENANCE PROCEDURES (Cont'd.)**

**4-12. STAND ASSY, REPAIR. (Cont'd.)**

**CLEANING AND INSPECTION**

**WARNING**

Dry-cleaning solvent, P-D-680, used to clean parts is potentially dangerous to personnel and property. Avoid inhalation of fumes and repeated or prolonged skin exposure. Wash exposed skin thoroughly with soap and water. Use in well ventilated area away from open flame or excessive heat. Flash point is 100°F (38°C).

- a. Wash all parts in cleaning solvent P-D-680 to remove all dirt and foreign matter. Dry with clean lint free cloth.
- b. Inspect nozzle stand assy in accordance with PMCS.
- c. Using proper tools, straighten any bent legs or brackets. Weld any minor cracks or breaks that were detected during inspection. Replace any leg or bracket that is damaged beyond repair.
- d. If either chain is damaged, cut a new one approximately 10-inches in length from bulk chain (P/N RRC-271).
- e. Replace any remaining parts that are damaged or defective.



Section V  
ORGANIZATIONAL MAINTENANCE PROCEDURES (Cont'd.)

4-12. STAND ASSY, REPAIR. (Cont'd.)

INSTALLION

- a. Install two clevis legs (5) on pivot leg (3) with clevis pins (4).
- b. Install two cotter pins (6) and bend back around heads so they will not snag on clothing or hoses.

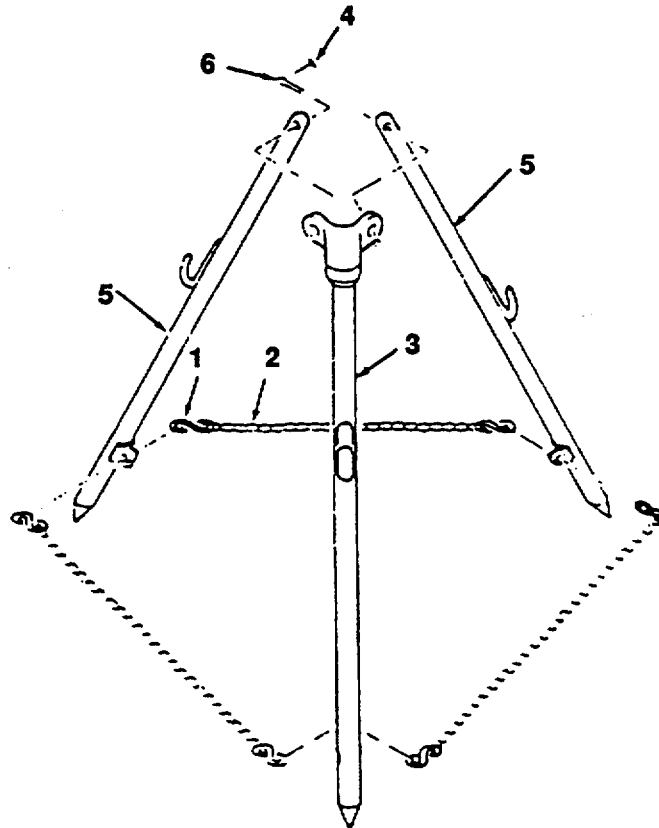

- c. Install new or repaired sash chains (2) with s-hooks (1) to stand legs (3/5).
- d. Bend shook inward with a pair of common pliers and return stand to service.
- e. Install stand assy back in FAWPSS system.

Section V  
ORGANIZATIONAL MAINTENANCE PROCEDURES (Cont'd.)

4-13. HOSE ASSYS, REPAIR

REMOVAL

NOTE

Repair of the hose assy is limited to replacement of defective parts.

- a. Remove damaged hose assy (1) from FAWPSS system.
- b. Remove cap (2) and plug (3) connection on system components and, hose assy (1).
- c. Cut hose clamps with diagonal cutters and remove them from the hose assy.
- d. Remove quick-disconnect coupling halves from the hose assy.
- e. Remove gasket (4) from female coupling half and dust cap.

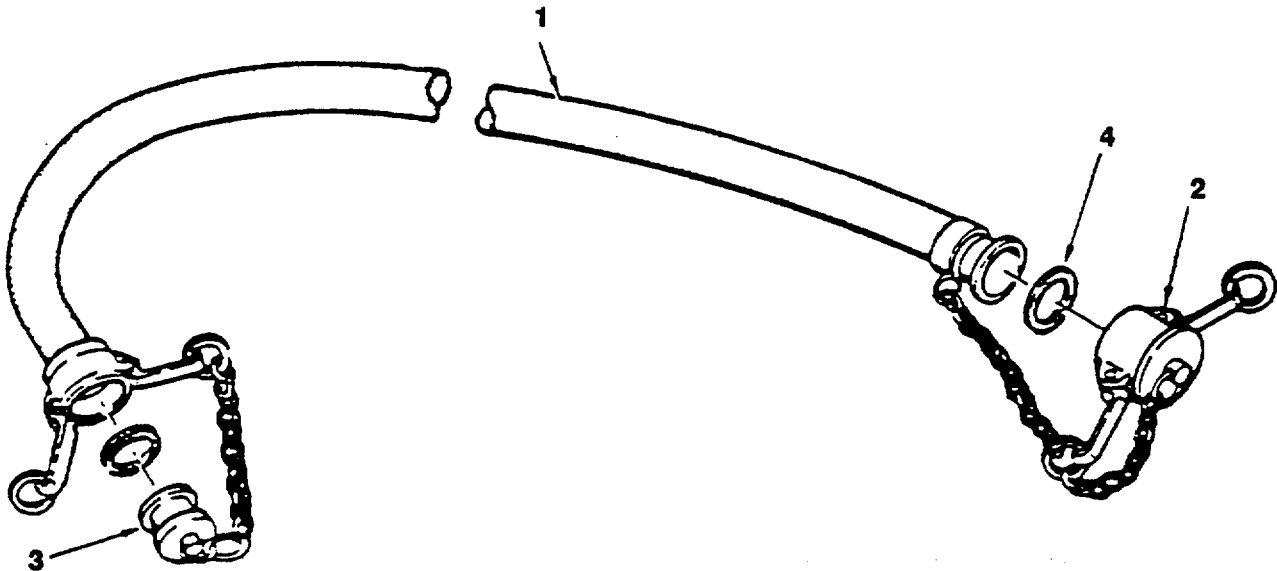

CLEANING AND INSPECTION

- a. Wash the hose and couplings in a mild soap and water solution. Rinse in clean water and dry with a clean lint-free cloth.
- b. Inspect hose and coupling assys.

## Section V ORGANIZATIONAL MAINTENANCE PROCEDURES (Cont'd.)

### 4-13. HOSE ASSYS, REPAIR (CONT).

#### INSTALLATION

- a. For reassembly use clamping tool, PN C001 (70847) supplied with the system kit.
- b. Insert coupling half into the hose. Cut a band of strapping that will extend 8 to 10 inches beyond end of buckle toothed slot.
- c. Hook the band over top of buckle between the prongs (4) bringing other end around hose and through buckle.
- d. Insert band end into tool slots. Nose of tool should fit snug against buckle (5).
- e. Apply tension on tool handle and gripper lever and position as required. Tool will self-lock when proper tension is applied (6).

#### CAUTION

Band may break if operator releases tension handle before backing off entire length of bend.

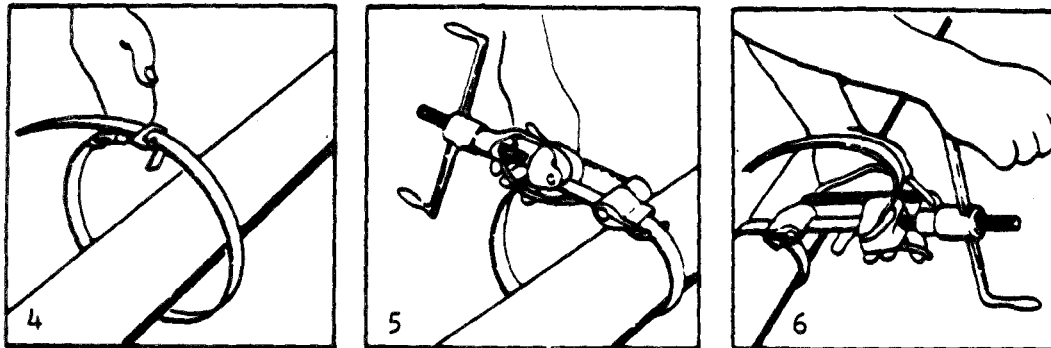

Section V  
ORGANIZATIONAL MAINTENANCE PROCEDURES (Cont'd.)

4-13. HOSE ASSYS, REPAIR (CONT).

- f. Bend band back over buckle teeth and release tension handle.
- g. Cut band with tools cutting handle (1) while holding end of band down with thumb (2).
- h. Secure stub by tapping prongs of buckle down with a hammer (3).
- i. Repeat steps a. through h. for each clamp installed.
- j. Install new gasket in female coupling halves and dust caps.
- k. Attach dust caps and plugs on the hose assy.
- l. Reinstall in water distribution system in the reverse order of removal.

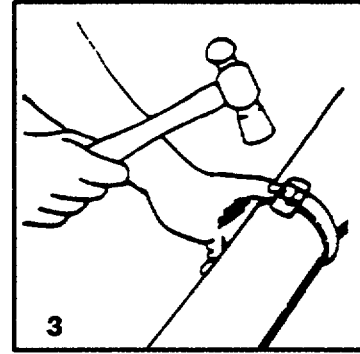
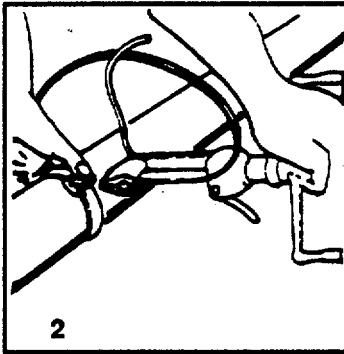
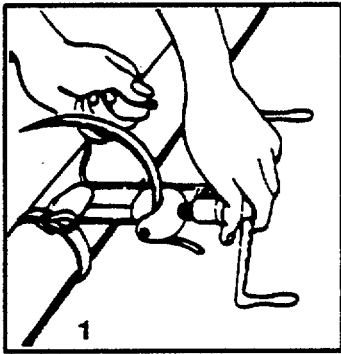

Section III  
ORGANIZATIONAL MAINTENANCE PROCEDURES (Cont'd.)

4-13.1 Towing and Lifting Yoke,

INSPECT AND CLEANING

WARNING

Drycleaning solvent, PD-680, used to clean parts is potentially dangerous to personnel and property. Use in well ventilated area as the fumes are dangerous if inhaled. Avoid repeated and prolonged skin contact. Do not use near open flame or excessive heat. Flash point of solvent is 100°F -138°F (38°C-59°C).

- a. Wash the towing and lifting yoke with drycleaning solvent (item 4 App. D), to remove foreign matter.
- b. Inspect connecting legs(1) and upper legs (2) for breaks, cracks, or bends.
- c. Inspect chains (10), pins (3,12, and 13) and hooks and key ring (11) for damage or missing parts.
- d. Inspect the two braces (5) for breaks, bends, or cracks,

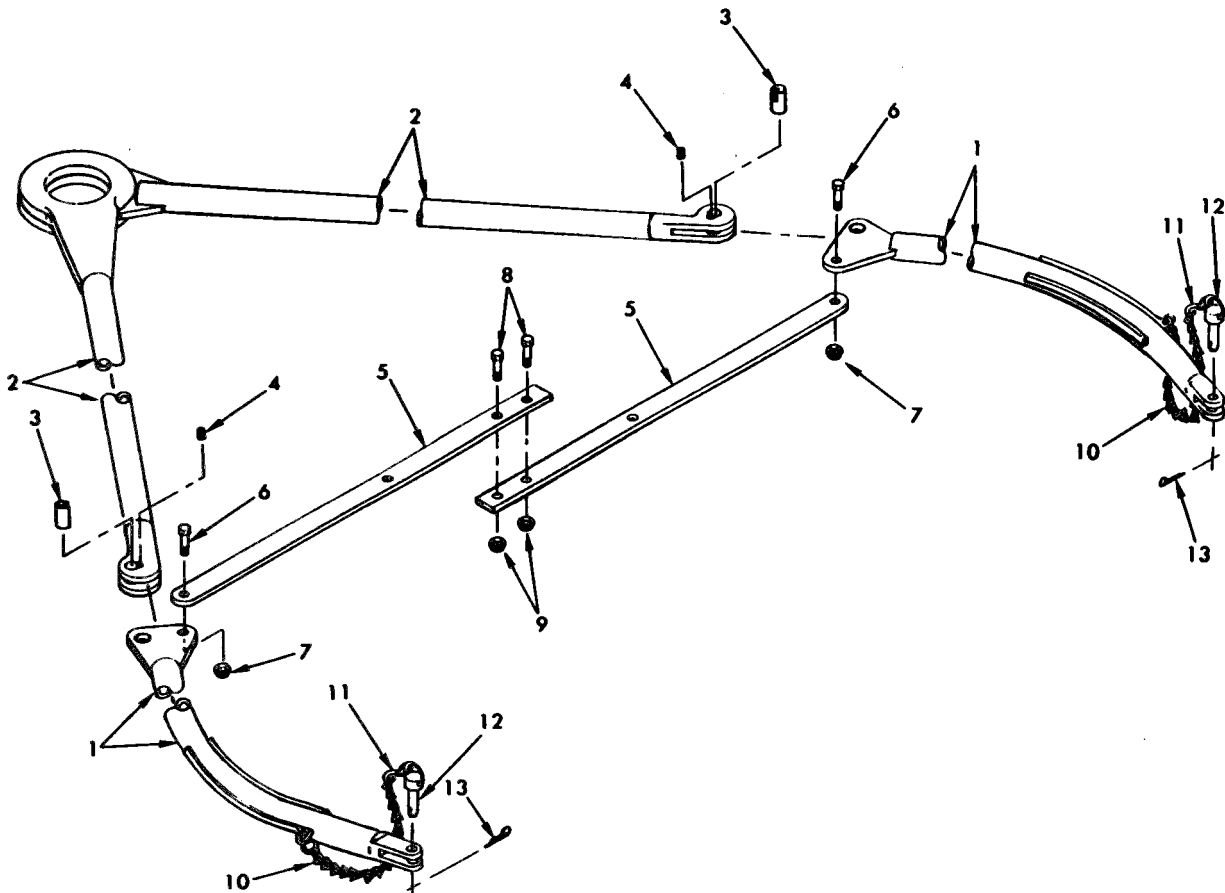

### NOTE

Only disassemble the parts of the yoke that require repair or replacement.

#### DISASSEMBLY

- a. Remove setscrews (4) and pins (3) and separate connecting legs (1) from upper legs (2).
- b. Remove screws (6) and nuts (7) and separate the two braces (5) from the connecting legs (1).
- c. If necessary, separate the two braces (5) by removing the cap screws (8) and nuts (9).
- d. Pull cotter pins (13) and remove clevis pins (12) hooks and key rings (11), and chains (10) from connecting legs.

#### REPAIR

- a. Using the proper tools, straighten any bent legs (1). (2) or braces (5). Weld any minor cracks or breaks that were detected during inspection. Replace any leg or brace that is damaged beyond repair.
- b. Replace any remaining parts that are damaged or defective.

#### ASSEMBLY

- a. Attach chains (10), hooks and key rings (11) and clevis pins (12) to connecting legs (1) and secure cotter pin (13).
- b. Connect the two braces (5) and install screws (8) and washers (9).
- c. Connect the two braces (5) to the connecting legs (1) and secure with screws (6) and nuts (7).
- d. Attach the upper legs (2) to the connecting legs (1) with pins (3) and setscrews (4).

**4-14. DISASSEMBLY AND REPACKAGING.** Disassemble this system in reverse of assembly. Perform the following prior to repackaging:

- a. Drain, dry, and then cap and plug all hose assys.
- b. Drain and dry all metal assys, such as valve and tee assys. Cap and plug these items, as applicable.
- c. Remove and retain the quick disconnect elbow from the suction and discharge side port nipples on the top of each of the water storage and dispensing drums. Then attach a protective cap to each of these two nipples.
- d. Drain each drum by turning the gate wheel on the drain assy which is attached to the drain fitting, in the tank bottom en, remove the drain hose assy and thread the protective plug into the drum drain fitting.
- e. Drain, collapse and fold each of the drums.

**NOTE**

The drums are now ready to be placed in suitable carrier or container.

- f. Remove drain plug on 125GPM pump and engine assy and drain water from pump. Install drain plug after water has been drained from pump.
- g. Deleted.

**Change 8 4-21/(4-22 blank)**





## CHAPTER 5

### DIRECT SUPPORT MAINTENANCE INSTRUCTIONS

#### Section I

### REPAIR PARTS, SPECIAL TOOLS, TMDE, AND SUPPORT EQUIPMENT

**5-1. COMMON TOOLS AND EQUIPMENT.** Refer to the Modified Table of Organization and Equipment (MTOE) applicable to your unit.

**5-2. SPECIAL TOOLS, TMDE, AND SUPPORT EQUIPMENT.** No special tools, TMDE, or support equipment are required for the FAWPSS system.

**5-3. REPAIR PARTS.** Repair parts are listed in Appendix C of this manual.

#### Section II.

### DIRECT SUPPORT MAINTENANCE TROUBLESHOOTING TABLE

#### 5-4. GENERAL.

**a.** This section provides information in diagnosing, and correcting unsatisfactory operation or failure of FAWPSS. Each malfunction is followed by a list of probable causes and actions to take to remedy the malfunction. You should perform the tests/inspections and corrective actions in the order listed.

**b.** This manual cannot list all malfunctions that may occur, nor all tests or inspections and corrective actions. If a malfunction is not listed or is not corrected by corrective actions, notify your supervisor.

*Table 5-1. Troubleshooting*

---

MALFUNCTION
TEST OR INSPECTION
CORRECTIVE ACTION

---

#### 1. 2-INCH VALVE ASSY

Inspect for cracked or dented female and male quick-disconnect coupling.

Replace with female or male quick-disconnect coupling. Refer to direct maintenance procedures 5.5.

Table 5-1. Troubleshooting (Cont'd.)

---

<b>MALFUNCTION</b>
<b>TEST OR INSPECTION</b>
<b>CORRECTIVE ACTION</b>

---

**2. NOZZLE DISTRIBUTION ASSY**

Step 1. Inspect for damaged or missing protective cap, chain, or spring.

Replace with serviceable protective cap, chain, and spring. Refer to direct maintenance procedures 5-6.

Step 2. Inspect for cracked or damaged female quick-disconnect reducer.

Replace with serviceable female quick-disconnect reducer. Refer to direct maintenance procedures 5-6.

Step 3. Inspect for damaged swivel.

Replace with serviceable swivel. Refer to direct maintenance procedures 5-6.

Step 4. Inspect for damaged control or nozzle.

Replace with serviceable nozzle. Refer to direct maintenance procedures 5-6.

### Section III DIRECT MAINTENANCE PROCEDURES

#### 5 - 5 . VALVE ASSY, REPAIR

##### REMOVAL

- a. Install valve in bench vice with protective pads.  
Using a 7/16" wrench remove nut (1), lockwasher (2)  
and handle (3) from gland nut (4).
- b. Remove gland nut (4) from body (8).
- c. Remove stem (5), ring (6) and packing (7).
- d. Using two 1/2" wrenches, loosen and remove four  
nuts (10) lockwashers (11) and bolts (9).
- e. Remove two end fittings (12) from body (8).
- f. Remove two body gaskets (13) ball (15) and two seats  
(14) from body (8). Remove stop pin (16) if required.

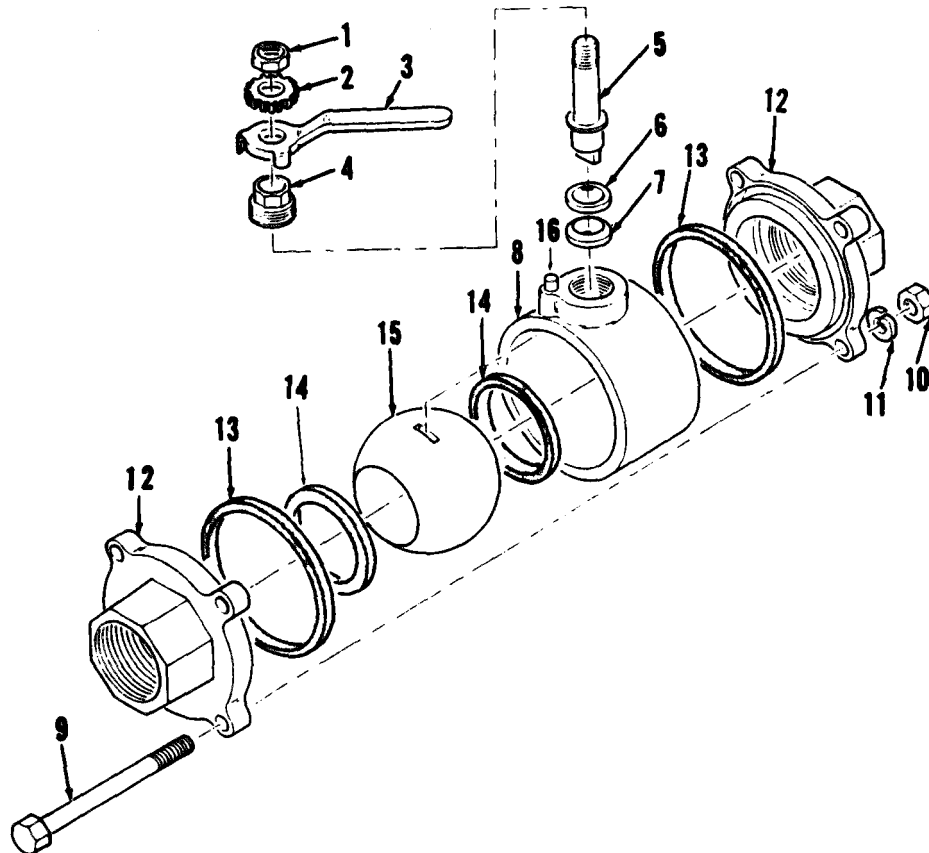

**Section III.**  
**DIRECT MAINTENANCE PROCEDURES (Cont'd.)**

**5-5. VALVE ASSY, REPAIR (Cont'd.)**

**INSPECTION AND CLEANING**

- a. Wash all parts in a mild soap and water solution and dry with a clean lint free cloth.
- b. Inspect all parts for cracks. wear or distortion and replace if required.
- c. Discard all gaskets and packing and replace with new ones.

**INSTALLATION**

- a. Install new packing (7) and ring (6) in upper body (8).
- b. Install ball (15) and align with stem (5).
- c. Install two seats (14), one on each side of ball (15).
- d. Place two body gaskets against the body (8) and install four bolts (9) lockwashers (11) and nuts (10). e. Using two 1/2" wrenches tighten four bolts (9) and nuts (10) snugly against body (8).
- f. Using 7/16" wrench install nut (4) on stem (5) and tighten snugly against body (8).
- g. Install handle (3) washer (2) and nut (1). Tighten snugly to top of handle (3).
- h. Return valve to service.

Section III  
DIRECT MAINTENANCE PROCEDURES (Cont'd.)

5-5. VALVE ASSY, REPAIR (Cont'd.)

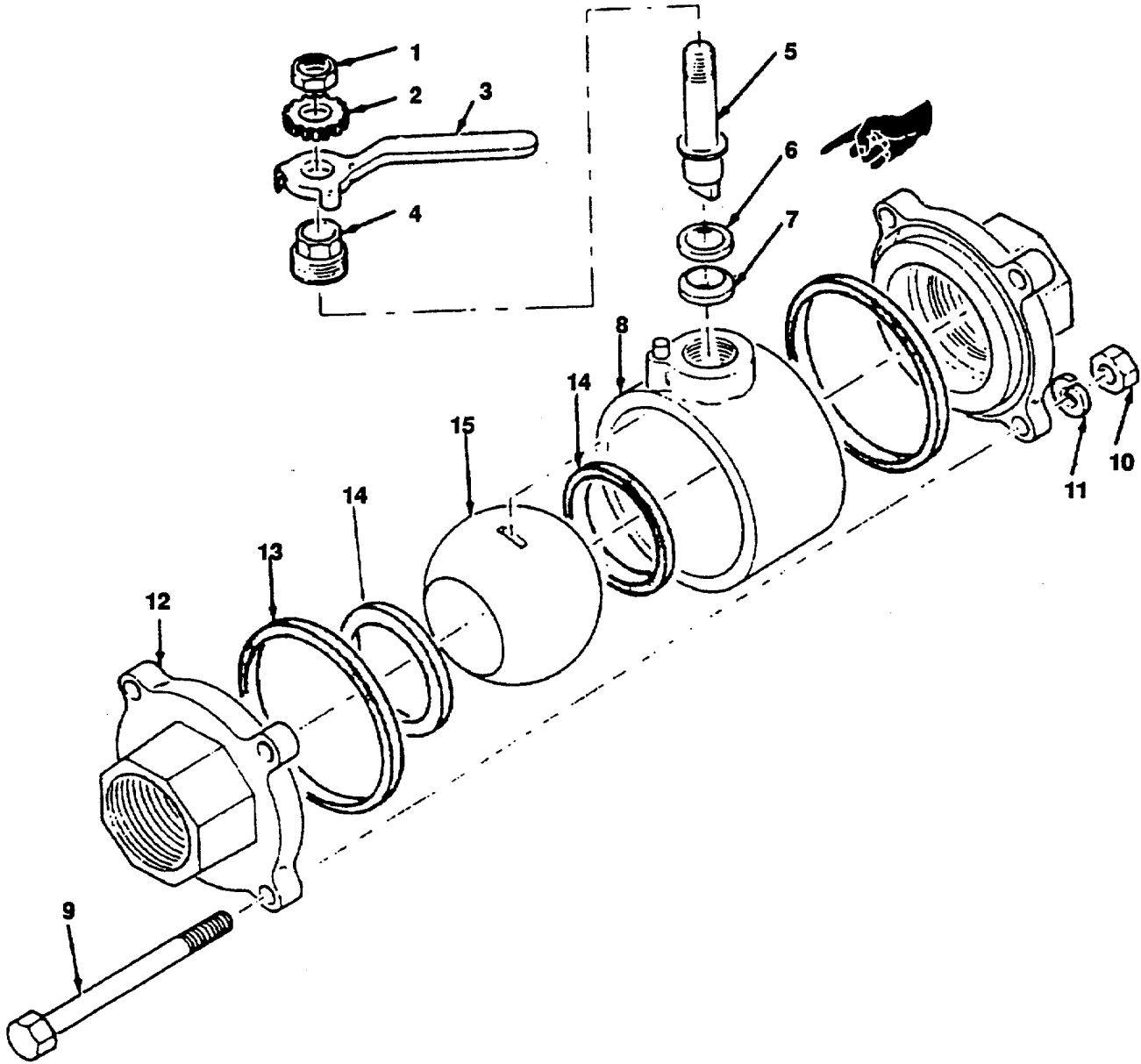

### Section III DIRECT MAINTENANCE PROCEDURES (Cont'd.)

#### 5-6. NOZZLE DISTRIBUTION ASSY, REPAIR

##### REMOVAL

- a. Install nozzle in bench vice using protective pads.
- b. Remove cap (1) with adjustable wrench.
- c. Remove main spring (2), spring guide (3), disc (4) skirts (5) and stem (6).
- d. Using common screwdriver remove spring retainer (7), spring (8), gland packing (9) and packing (10).
- e. Slide lever (12) out of guides in body (11).
- f. Using adjustable wrench, remove adapter (13).
- g. Using common screwdriver, pry open retaining link (14) and remove chain (15) drawbar (17), spring (16) and dust cap (18).
- h. Using adjustable wrench loosen locknut (19) and unscrew spout (21), and adapter (20).

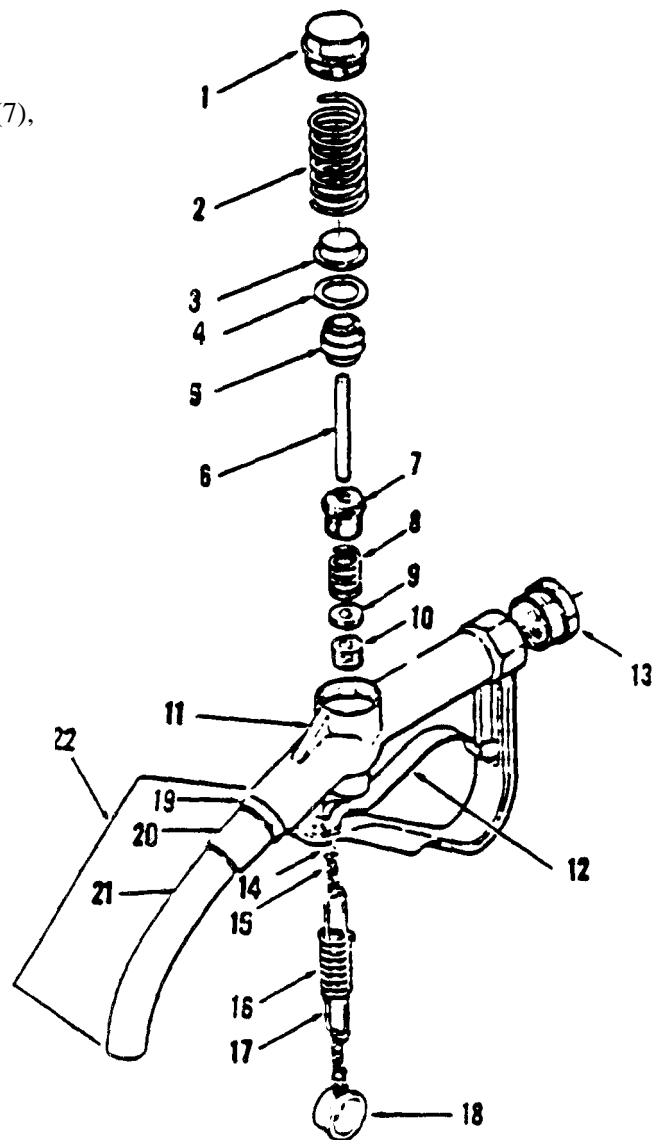

##### INSPECTION AND CLEANING

- a. Wash all parts in a mild soap and water solution and dry with a clean lint free cloth.

Section III  
DIRECT MAINTENANCE PROCEDURES (Cont'd.)

5-6. NOZZLE DISTRIBUTION ASSY, REPAIR (Cont'd.)

- b. Inspect all parts for cracks, wear, and damage.
- c. Replace all packings and unserviceable parts.

**INSTALLATION**

- a. Install nozzle spout (21) and adapter (20) on body (11).
- b. Using adjustable wrench, tighten locknut (19) snugly against body (11) ensuring spout (21) is properly positioned.
- c. Install dustcap (18) drawbar (17) spring (16) and chain (15).
- d. Using common pliers, install two retaining links (14) and squeeze ends shut until they are just touching.
- e. Wrap end of adapter (13) with one layer of teflon tape ST410.
- f. Using adjustable wrench install adapter (13) into body (11). Tighten snugly against body.

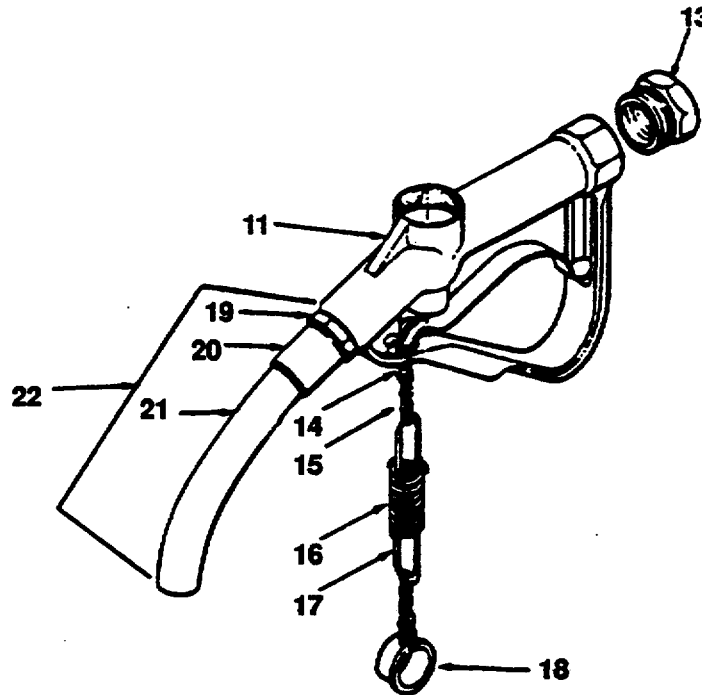

### Section III DIRECT MAINTENANCE PROCEDURES (Cont'd.)

#### 5-6. NOZZLE DISTRIBUTION ASSY, REPAIR (Cont'd.)

- g. Install lever (12) into guides on valve body (11).
- h. Install packing (10), gland packing (9), spring (8), and spring retainer (7) into body (11).
- i. Using common screwdriver and steady downward pressure, screw spring retainer (7), into valve body (11) until it bottoms out.
- j. Install stem (6), skirt (5), disc (4) and spring guide (3) into upper body (11).
- k. Using adjustable wrench, install main spring (2) and use downward pressure and install cap (1). Tighten cap snugly against body (11).
- l. Return nozzle to service.

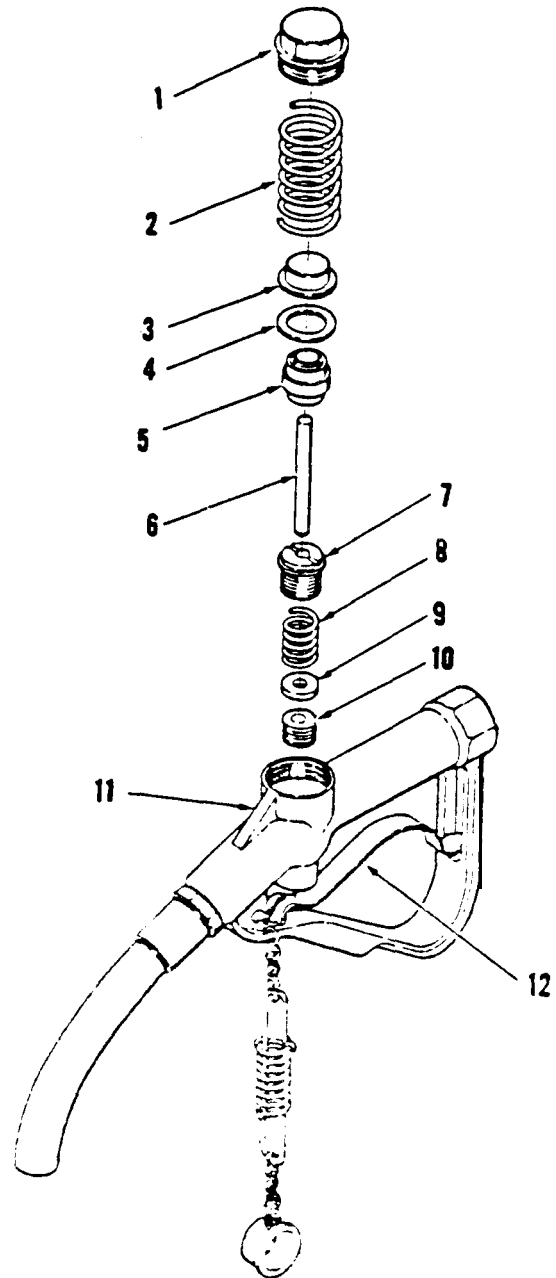



## APPENDIX A REFERENCES

---

### A-1. DEMOLITION

TM 750-244-3 Destruction of Equipment to Prevent Enemy Use

### A-2. MAINTENANCE

FM 10-69 Petroleum Handling Equipment and Operation

FM 10-564 Air Drop of Supplies and Equipment

TM 10-8110-202-13&P Operator's Organizational, and Direct Support Maintenance Manual and Repair Parts and Special Tools List: Dmm, Fabric, Collapsible, Drinking Water, 500 Gallon Capacity, Model RD-610 (NSN 8110-01-122-0015)

TM 9-2805--257-14 Operator, Unit, Direct Support and General Support Maintenance Manual: Engine, Gasoline, 3 HP, Military Standard Models

TM 5-4320-208-12&P Organizational Maintenance: Pump, Centrifugal, Gasoline Engine Driven, Frame Mtd., 2-Inch 125 GPM, 50-Foot Head

TM 5-4320-309-14 Operator, Unit, Direct Support, and General Support Maintenance for Pump Unit, Centrifugal, Self-Priming, 125 GPM Water, Class 3, Diesel-Driven

FM 10-52 Field Water Supply

DA PAMPHLET 738-750 The Army Maintenance Management System

### A-3. PAINTING

AR 38-250 Packaging and Handling of Dangerous Materials for Transportation by Military Aircraft

TM 740-90-1 Administrative Storage of Equipment

SB-740-99-1 Storage and Servicing Standard for TSARCOM Material



## Appendix B. MAINTENANCE ALLOCATION CHART (MAC)

---

### Section I. INTRODUCTION

#### **B-1. THE ARMY MAINTENANCE SYSTEM MAC**

a. This introduction (section I) provides a general explanation of all maintenance and repair functions authorized at various maintenance levels under the standard Army Maintenance System concept.

b. the maintenance Allocation Chart (MAC) in section II designates overall authority and responsibility for the performance of maintenance functions on the identified end item or component. The application of the maintenance functions to the end item or component will be constant with the capacities and capabilities of the designated maintenance levels, which are shown in the MAC in column (4) as:

Unit - includes two subcolumns C (operator/crew) and O (unit) maintenance.

Direct Support - includes an F subcolumn.

General Support - includes an H subcolumn.

Depot - includes an D subcolumn.

c. Section III lists the tools and test equipment (both special tools and common tools sets) required for each maintenance function as referenced from section II.

d. Section IV contains supplemental instructions and explanatory notes for a particular maintenance function.

#### **B - 2. MAINTENANCE FUNCTIONS. MAINTENANCE FUNCTIONS WILL BE LIMITED TO AND DEFINED AS FOLLOWS**

a. Inspect. To determine the serviceability of an item by comparing its physical, mechanical, and/or electrical characteristics with established standards through examination (i.e., by sight, sound, or feel).

b. Test. to verify Serviceability by measuring the mechanical or electrical characteristics of an item and comparing those characteristics with prescribed standards.

c. Service. Operations required periodically to keep an item in proper operating condition, i.e., to clean (includes decontamination, when required), to preserve, to paint, or to replenish fuel, lubricants, chemical fluids, or gases.

d. Adjust. To maintain or regulate, within prescribed limits, by bringing into proper or exact position, or by setting the operating characteristics to specified parameters.

e. Align. To adjust-d variable elements of an item to bring about optimum or desired performance.

f. Calibrate. To determine and cause corrections to be made or to be adjusted on instruments or test, measuring, and diagnostic equipment used in precision measurement. Consists of comparisons of two instruments, one of which is a certified standard of known accuracy, to detect and adjust any discrepancy in the accuracy of the instrument being Compared.

g. remove/install. To remove and install the same item when required to perform service or other maintenance functions. It may be the act of emplacing, seating, or fixing into position a spare, repair part, or module (component or assembly) in a manner to allow the proper functioning of an equipment or system.

h. Replace. To remove an unserviceable item and install a serviceable counterpart in its place. Replace is authorized by the MAC and is shown as the 3rd position code of the SMR code.

i. **Repair.** The application of maintenance services<sup>1</sup> including fault location/troubleshooting<sup>2</sup>, removal/installation, and disassembly/assembly<sup>3</sup> procedures, and maintenance actions<sup>4</sup> to identify troubles and restore serviceability to an item by correcting specific damage, fault, malfunction, or failure in a part, subassembly, module (component or assembly), and item, or system.

j. **Overhaul.** That maintenance effort (service/action) prescribed to restore an item to a completely serviceable/operational condition as required by maintenance standards in appropriate technical publications (i.e., DMWR). Overhaul is normally the highest degree of maintenance performed by the Army. Overhaul does not normally return an item to like new condition.

k. **Rebuild.** Consists of those service/actions necessary for the restoration of unserviceable equipment to a like-new condition in accordance with original manufacturing standards. Rebuild is the highest degree of material maintenance applied to Army equipment. The rebuild operation includes the act of returning to zero those age measurements (hours, miles, etc.) considered in classifying Army equipment and components.

### **B-3. EXPLANATION OF COLUMNS IN THE MAC, SECTION II.**

a. **Column 1- Group Number.** Column 1 lists functional group code numbers, the purpose of which is to identify maintenance significant components, assemblies, subassemblies, and modules with the next higher assembly.

b. **Column 2- Component/Assembly.** Column 2 contains the names of components, assemblies, subassemblies, and modules for which maintenance is authorized.

c. **Column 3- Maintenance Function.** Column 3 lists the functions to be performed on the item listed in column 2. (For detailed explanation of these functions, see paragraph B-2.)

---

<sup>1</sup>Service - Inspect, test, service, adjust, align, calibrate, and/or replace

<sup>2</sup>Fault location/troubleshooting - The process of investigating and detecting the cause of equipment malfunctioning; the act of isolating a fault within a system or unit under test (UUT).

<sup>3</sup>Disassembly/assembly - The step-by-step breakdown (taking apart) of a spare/functional group coded item to the level of its least component, that is assigned as SMR code for the level of maintenance under consideration (i.e., identification as maintenance significant).

<sup>4</sup>Actions - Welding, grinding, riveting, straightening, facing, machining, and/or resurfacing.

d. Column 4 - Maintenance Category. Column 4 specifies, by the listing of a work time figure in the appropriate subcolumn(s), the category of maintenance authorized to perform the function listed in Column 3. This Figure Represents the active time required to perform that maintenance function at the indicated category of maintenance. If the number or complexity of the tasks within the listed maintenance function varies at different maintenance categories appropriate work time figures will be shown for each category. The work time figure represents the average time required to restore an item (assembly subassembly, component, module, end item, or system) to a serviceable condition under typical field Operating conditions. This time includes preparation time (including any necessary disassembly/assembly time), troubleshooting/fault time, quality assurance/quality control time in additions to the time required to perform the specific tasks identified for the maintenance functions authorized in the maintenance allocation chart. The symbol designations for the various maintenance categories areas follows:

- Operator or Crew
- C Unit Maintenance
- F Direct support Maintenance
- H General support Maintenance
- D Depot Maintenance

e. Column 5 - Tool and Equipment. Column 5 specifies, by code, those common tool sets (not individual tools) and special tools, TMDE, end support equipment required to perform the designated function.

f. Column 6 - Remarks. This column shall, when applicable, contain a letter code, in alphabetic order, which shall be keyed to the remarks contained in section IV.

**B-4. EXPLANATION OF COLUMNS IN TOOL AND TEST EQUIPMENT REQUIREMENTS SECTION III.**

a. Column 1 - Reference Code. The tool and test equipment reference code correlates with a code used in the MAC, section II, column 5.

b. column 2 - maintenance Category. - lowest category of maintenance authorized to use the tool or test equipment

c. Column 3.- Nomenclature name or identification of the tool or test equipment.

d. Column 4- national stock number. The National stock number of the tool or test equipment.

e. Column 5-Tool Number. The manufacturer's part number.

**B-5. EXPLANATION OF COLUMNS IN REMARKS SECTION V.**

a. Column 1-Reference code. The code recorded in column 6, section II.

b. Column 2 - Remarks. This column lists information pertinent to the maintenance function being performed as indicated in the MAC, section II

Section II. MAINTENANCE ALLOCATION CHART

(1) GROUP NUMBER	(2) COMPONENT/ ASSEMBLY	(3) MAINTENANCE FUNCTION	(4) MAINTENANCE LEVEL					(5) TOOLS AND EQUIPMENT	(6) REMARKS
			UNIT		DS	GS	DEPOT		
			C	O	F	H	D		
01	VALVE ASSEMBLY	INSPECT REPLACE REPAIR	0.3	0.5 1.0				1 1	
02	NOZZLE DISTRIBUTION ASSY	INSPECT REPLACE REPAIR	0.1	0.3 1.5				1 1	
03	STAND ASSEMBLY	INSPECT REPLACE REPAIR	0.1 0.3	0.5				1 1	
04	HOSE ASSEMBLY	INSPECT REPLACE REPAIR	0.1 0.3	1.0				1 1,2	
05	WATER DRUM ASSEMBLY								A
06	125 GPM CENTRIFU- GAL PUMP ASSEMBLY								B
	3HP GASOLINE EN- GINE 125 GPM PUMP ASSEMBLY								C
07	TOWING AND LIFTING YOKE ASSEMBLY	INSPECT REPLACE REPAIR	0.2 0.5	1.0				1	
08	MISCELLANEOUS ITEMS								D

**Section III. TOOLS AND TEST EQUIPMENT REQUIREMENTS**

TOOL OR TEST EQUIPMENT REF CODE	MAINTENANCE CATEGORY	NOMENCLATURE	NATIONAL/NATO STOCK NUMBER	TOOL NUMBER
1	O	Tool Kit, General Mechanic's	5180-00-177-7033	SC 5180-90-CL-N26 (19099)
2	O	Clamping Tool, Strap Band, Hose: Size of strap for which designed; 3/8 IN to 5/8 IN. range, 1/64 IN. to 1/32 IN. thk range; furnished with ratchet tension wrench.	5120-00-359-6587	S38 (70847)

**Section IV. REMARKS**

Reference Code	REMARKS
A	REFER TO TM 10-8110-202-13&P FOR MAINTENANCE OF FABRIC DRUM ASSEMBLIES
B	FOR MODEL WPSS100, REFER TO TM 5-4320-208-12P FOR MODEL 9095-1, REFER TO TM 5-4320-309-14 AND 5-4320-309-24P
C	FOR MODEL WPSS100, REFER TO TM 5-4320-257-14
D	REPAIR OF MISCELLANEOUS COMPONENTS IS LIMITED TO THE REPLACEMENT OF CAPS GASKETS AND KEY RINGS





APPENDIX C

OPERATORS, UNIT, AND DIRECT SUPPORT  
 MAINTENANCE REPAIR PARTS AND SPECIAL TOOLS LIST

Section I. INTRODUCTION

1. SCOPE. This RPSTL lists and authorizes spares and repair parts; special trek; special test, measurement, and diagnostic equipment (TMDE); and other special support equipment required performance of operator's, unit, and direct support maintenance of the Forward Area Water Point Supply System. It authorizes the requisitioning, issue, and disposition of spares, repair parts and special tools as indicated by the source, maintenance and recoverability (SMR) codes.

2. GENERAL tin to this section, Introduction, this Repair Parts and Special Tools List is divided into the following sections:

a. Section II. Repair parts List. A list of spares and repair parts authorized by this RPSTL for use in the performance of maintenance. This list also includes parts which must be removed for replacement of the authorized parts. Parts lists are composed of functional groups in ascending alphanumeric sequence, with the parts in each group listed in ascending figure and item number sequence. Bulk materials are listed in item name sequence. Items are shown in the associated illustration(s)/figure(s).

b. Section III. Special Tools List. A list of special tools, special TMDE, and other special support equipment authorized by this RPSTL (as indicated by basis of Issue (BOI) informaion in DESCRIPTION AND USABLE ON DODE column) for the performance of maintenance.

c. Section IV. Cross-References Indexes. A list, in National Item identification Number (NIIN) sequence, of all National stock numbered items appearing in the listing, followed by a list in alphanumeric sequence of all part numbers appearing in the listings. National stock numbers and part numbers cross referenced to each illustration figure and item number appearance. The figure and item number index lists figure and item numbers in asphanumeric sequence and cross references NSN, CAGEC and part number.

3. EXPLANATION OF COLUMNS (SECTIONS II AND III).

A. ITEM NO. (COLUMN (1)). Indicates the number used to identify items called out in the illustration.

b. SMR Code (Column (2)). The Source, Maintenance, and Recoverability (SMR) code is a 5-position code containing supply/requisitioning information, maintenance category authorization criteria, and disposition instruction, as shown, in the following breakout.

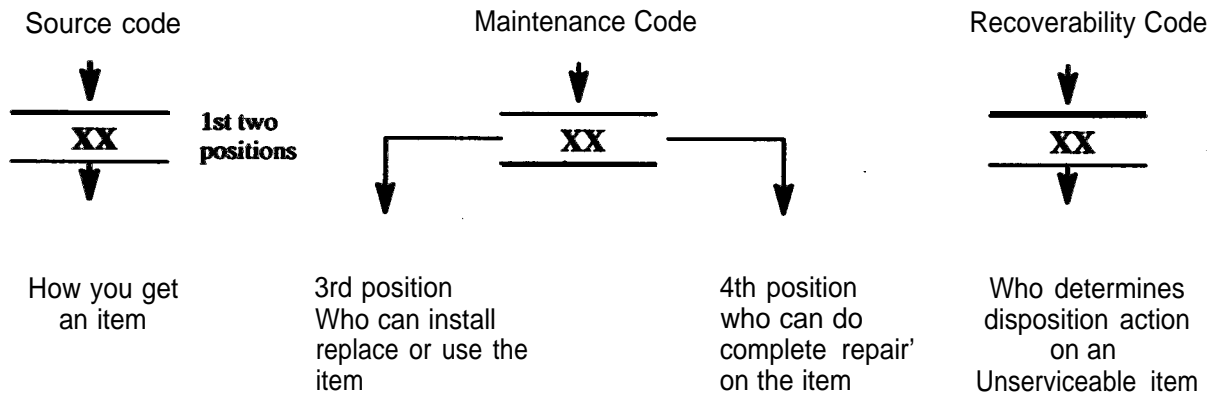

Complete Repair: Maintenance capacity, capability, and authority to perform all corrective maintenance tasks of the "Repair" function in a use/user environment in order to restore serviceability to a failed item.

(1) Source Code. The source code tells you how to get an item needed for maintenance, repair, or overhaul of an end item/equipment. Explanations of source codes follows:

Source Code	Explanation
PA PB PC**	Stocked items; use the applicable NSN to request/requisition items with these source codes. They are authorized to the category indicated by the code entered in the 3rd position of the SMR code.  **NOTE: items coded PC are subject to deterioration.
PD PE PF PG	
KD KF KB	Items with these codes are not to be requested/requisitioned individually. They are part of a kit which is authorized to the maintenance category indicated in the 3rd position of the SMR code. The complete kit must be requisitioned and applied.

MO - (Made at Unit/AVUM Level)	Items with these codes are not to be requested/requisitioned individually. They must be made from bulk material which is identified by the part number in the DESCRIPTION and USABLE ON CODE (UOC) column and listed in the Bulk Material group of the repair parts list in this RPSTL. If the item is authorized to you by the 3rd position code of the SMR code, but the source code indicates it is made at a higher level, order the item from the higher level of maintenance.
MF - (Made at DS/AVUM Level)	
MH - (Made at GS Level)	
ML - (Made at Specialized Repair Activity (SRA))	
MD - (Made at Depot)	
AO - (Assembled by Unit/AVUM Level)	Items with these codes are not to be requested/requisitioned individually. The parts that make up the assembled item must be requisitioned or fabricated and assembled at the level of maintenance indicated by the source code. If the 3rd position code of the SMR code authorizes you to replace the item, but the source code indicates the items are assembled at a higher level, order the item from the higher level of maintenance.
AF - (Assembled by DS/AVIM Level)	
AH - (Assembled by GS Category)	
AL - (Assembled by SRA)	
AD - (Assembled by Depot)	

XA - Do not requisition "XA"-coded item. Order its next higher assembly. (Refer to the NOTE below.)

XB - If an "XB" item is not available from salvage, order it using the CAGEC and part number given.

XC - Installation drawing, diagram, instruction sheet, field service drawing, that is identified manufacturer's part number.

XD - Item is not stocked. Order an "XD"-coded item through normal supply channels using the CAGEC and part number given, if no NSN is available.

**NOTE**

Cannibalization or controlled exchange, when authorized, maybe used as a source of supply for items with the above source codes, except for those source coded "XA" or those aircraft support items restricted by requirements of AR 750-1.

(2) maintenance code Maintenance codes tell you the level(s) of maintenance authorized to USE and REPAIR support items. The maintenance codes are entered in the third and fourth positions of the SMR code as follows:

(a) The maintenance code entered in the third position tells you the lowest maintenance level authorized to remove, replace, and use an item. The maintenance code entered in the third position will indicate authorization to the following levels of maintenance.

**Maintenance**

<b>Code</b>	<b>Application/Explanation</b>
C -	Crew or maintenance done within unit/AVUM maintenance.
O -	Unit level/AVUM maintenance can remove, replace, and use the item.
F -	Direct support/AVIM maintenance can remove, replace, and use the item.
H -	General support maintenance can remove, replace, and use the item.
L -	specialized repair activity can remove, replace, and use the item.
D -	depot can remove, replace, and use the item.

(b) The maintenance code entered in the fourth position tells whether or not the item is to be repaired and identifies the lowest maintenance level with the capability to do complete repair (i.e., perform all authorized repair functions)

**NOTE**

some limited repair may be done on an item at a lower level of maintenance, if authorized by the Maintenance Allocation Chart and SMR codes.

**Maintenance**

<b>Code</b>	<b>Application/Explanation</b>
O -	Unite/AVUM is the lowest level that can do complete repair of the item.
F -	Direct support/AVIM is the lowest level that can do complete repair of the item.
H -	General support is the lowest level that can do complete repair of the item.
L -	Specialized repair activity is the lowest level that can do complete repair of the item.
D -	Depot is the lowest level that can do complete repair of the item.
Z -	Nonreparable. No repair is authorized.
B -	No repair is authorized. No parts or special tools are authorized for the maintenance of a "B" coded Item. However, the item may be reconditioned by adjusting, lubricating, etc., at the user level.

(3) Recoverability code. Recoverability codes are assigned to items to indicate the disposition action on unserviceable items. The recoverability code is entered in the fifth position of the SMR Code as follows:

**Recoverability Codes**

<b>Code</b>	<b>Application/Explanation</b>
Z -	Nonreparable Items. When unserviceable, condemn and dispose of the item at the level of maintenance shown in 3d position of SMR Code.
O -	Reparable item. When not economically repairable, condemn and dispose of the item at unit Or AVUM level.
F -	Reparable item. When uneconomically repairable, condemn and dispose of the item at the direct support or AVIM level.

- H - Repairable item. When uneconomically repairable, condemn and dispose of the item at the general support level.
- D - Repairable item. When beyond lower level repair capability, return to depot. Condemnation and disposal of item not authorized below depot level.
- L - Repairable item. Condemnation and disposal not authorized below specialized repair activity (SRA).
- A - Item requires special handling or condemnation procedures because of specific reasons (e.g., precious metal content, high dollar value, critical material, or hazardous material). Refer to appropriate manuals/directives for specific instructions.
- c. CAGEC (Column (3)). The Commercial and Government Entity Code (CAGEC) is a 5-digit numeric code which is used to identify the manufacturer, distributor, or Government agency/activity that supplies the item.
- d. PART NUMBER (Column (4)). Indicates the primary number used by the manufacturer, (individual, company, firm, corporation, or Government activity), which controls the design and characteristics of the item by means of its engineering drawings, specifications, standards, and inspection requirements to identify an item or range of items.

NOTE

When you use an NSN to requisition an item, the item you receive may have a different part number from the number listed.

e. DESCRIPTION AND USABLE ON CODE (UOC) (Column (5)). This column includes the following information:

(1) The Federal item name and, when required, a minimum description to identify the item.

(2) Part numbers of bulk materials are referenced in this column in the line entry to be manufactured/fabricated.

(3) The statement "END OF FIGURE" appears just below the last item description in Column (5) for a given figure in both Section II and Section III.

f. QTY (Column (6)). The QTY (quantity per figure) column indicates the quantity of the item used in the breakout shown on the illustration/figure, which is prepared for a functional group, subfunctional group, or an assembly. A "V" appearing in this column instead of a quantity indicates that the quantity is variable and may vary from application to application.

4. EXPLANATION OF INDEX FORMAT AND COLUMNS (SECTION IV).

a. NATIONAL STOCK NUMBER (NSN) INDEX.

(1) STOCK NUMBER Column. This column lists the NSN in national item identification number (NIIN) sequence. The NIIN consists of the last nine digits of the NSN, i.e.

NSN  
5305-01-574-1467  
NIIN

When using this column to locate an item, ignore the first four digits of the NSN. Use the complete NSN (13 digits) when requisitioning items by stock number.

(2) FIG. Column. This column lists the number of the figure where the item is identified/located. The figures are in numerical order in Section II and Section III.

(3) ITEM column. The item number identifies the item associated with the figure listed in the adjacent FIG. column. This item is also identified by the NSN listed on the same line.

b. PART NUMBER INDEX. Part numbers in This index are listed by part number in ascending alpha-numeric sequence (i e., vertical arrangement of letter and number combination which places the first letter or digit of each group in order A through Z, followed by the numbers 0 through 9, and each following letter or digit in like order).

(1) CAGEC Column. The Commercial and Government Entity Code (CAGEC) is a 5-digit numeric code used to identify the manufacturer, distributor, or Government agency/activity that supplies the item.

(2) PART NUMBER Column. Indicates the primary number used by the manufacturer (individual, firm, corporation, or Government activity), which controls the design and characteristics of the item by means of its engineering drawings, specifications, standards, and inspection requirements to identify an item or range of items.

(3) STOCK NUMBER Column. This column lists the NSN for the associated part number and manufacturer identified in the PART NUMBER and CAGEC columns to the left.

(4) FIG. Column. This column lists the number of the figure where the item is identified/located in Section II and Section III.

(5) ITEM Column. The item number is that number assigned to the item as it appears in the figure referenced in adjacent figure number column.

c. FIGURE AND ITEM NUMBER INDEX.

(1) FIG. Column. This column lists the number of the figure where the item is identified/located in Section II and Section III.

(2) ITEM Column. The item number is that number assigned to the item as it appears in the figure referenced in the adjacent figure number column.

(3) STOCK NUMBER Column. This column lists the NSN for the item.

(4) CAGEC Column. The Commercial and Government Entity Code (CAGEC) is a 5-digit numeric code used to identify the manufacturer, distributor, or Government agency/activity that supplies the item.

(5) PART NUMBER Column. Indicates the primary number used by the manufacturer (individual, firm, corporation, or Government activity), which controls the design and characteristics of the item by means of its engineering drawings, specifications, standards, and inspection requirements to identify an item or range of items.

5. SPECIAL INFORMATION.

a. USABLE ON CODE The usable on code appears in the lower left corner of the Description Column heading. Usable on codes are shown as "UOC:.." in the Description Column (justified left) on the last line of the applicable item description/nomenclature. Uncoded items are applicable to all models.

b. FABRICATION INSTRUCTIONS. Bulk materials required to manufacture items are listed in the Bulk Material Functional Group of this RPSTL Part number for bulk materials are also referenced in the description column of the line entry for the item to be manufactured/fabricated.

c. INDEX NUMBERS. Items which have the word BULK in figure column will have an index number shown in the item number column. This index number is a cross-reference between the National Stock Number/part Number Index and the bulk material list in Section II.

6. HOW TO LOCATE REPAIR PARTS

a. When National Stock Numbers or Part Numbers are NOT Known.

(1) First Using the table of contents, determine the assembly or subassembly group to which the item belongs. This is necessary since figures are prepared for assembly groups and subassembly groups, and listings are divided into the same groups.

(2) Second. Find the figure covering the assembly group or subassembly group to which the item belongs.

(3) Third. Identify the item on the figure and use the Figure and Item Number Index to find the NSN.

b. When National Stock Number or Part Number is Known.

(1) First Using the of National Stock Number and Part Number Indexes find the pertinent National Stock Number or Part Number. The NSN index is in National Item Identification Number (NIIN) sequence (see paragraph 4.a.). The part numbers in the Part Number index are listed in ascending alphanumeric sequence see paragraph 4.b.). Both indexes cross-reference you to the illustration/figure and item number of the item you are looking for.

(2) Second. Turn to the figure and item number, verify that the item is the one you are looking for, then locate the item number in the repair parts list for the figure.

7. ABBREVIATIONS. Abbreviations used in this manual are listed in MIL-STD-12.



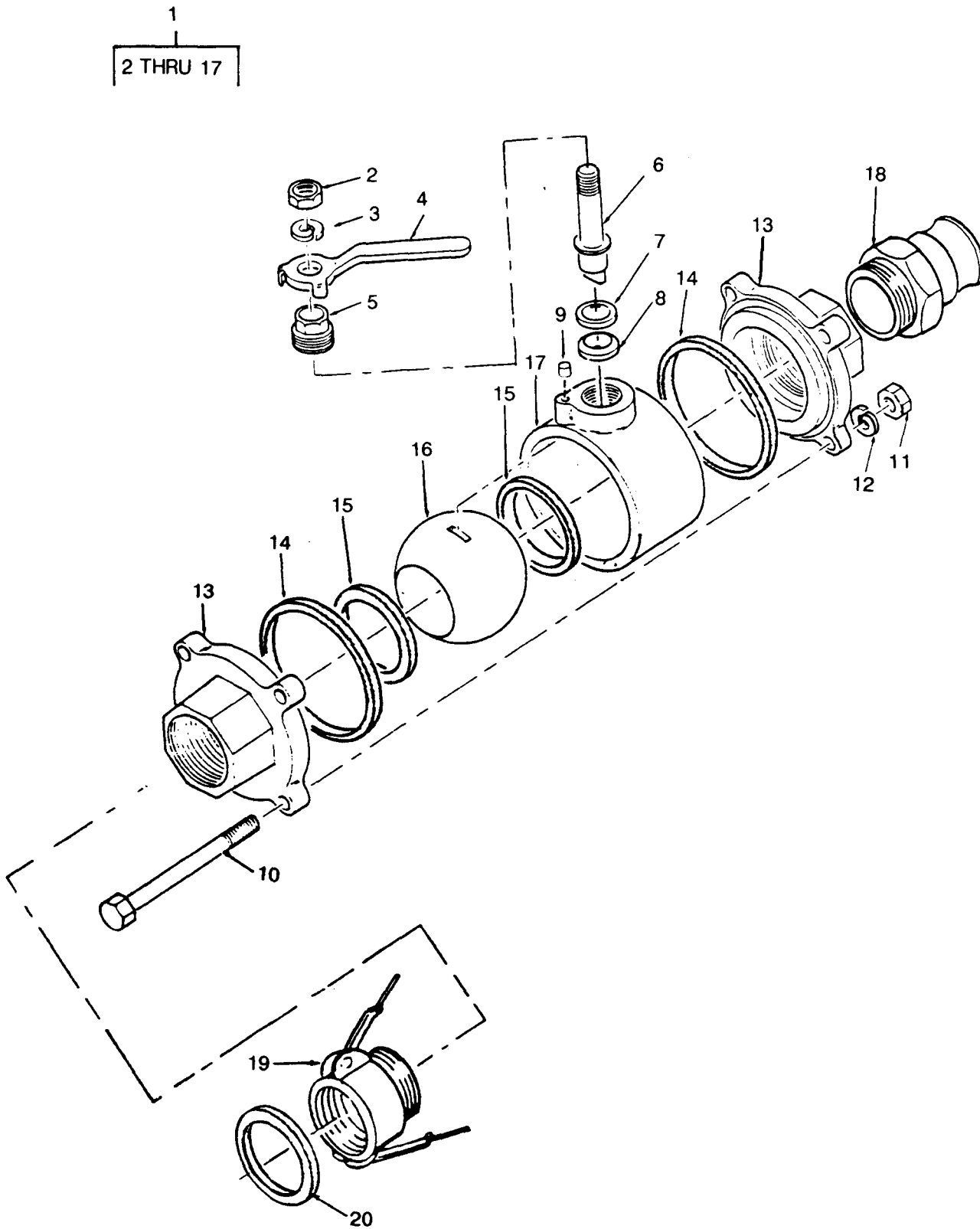

Figure 1. Ball Valve, Quick Acting



SECTION II		TM5-4320-301-13&P				
(1)	(2)	(3)	(4)	(5)	(6)	
ITEM	SMR		PART			
NO	CODE	CAGEC	NUMBER	DESCRIPTION AND USABLE ON CODES (UOC)		QTY
GROUP 01 VALVE ASSEMBLY						
FIG. 1 BALL VALVE, QUICK ACTING						
1	PBOOZ	97403	13225E9137-2	VALVE,BALL		2
2	XBOZZ	92021	SP-17-17	.NUT,PLAIN,OCTAGON		1
3	XBOZZ	92021	SP-17-44	.WASHER,LOCK		1
4	XDOZZ	92021	SP-17-4	.LEVER,MANUAL		1
5	XDOZZ	92021	SP-17-6	.RETAINER,PACKING		1
6	XDOZZ	92021	SP-17-5A	.STEM,FLUID VALVE		1
7	XBOZZ	92021	SP-17-10	.RETAINER,PACKING		1
8	XDOZZ	92021	SP-17-9	.PACKING,PREFORMED		1
9	XDOZZ	92021	SP-17-21	.PIN,STOP		1
10	XBOZZ	92021	SP-17-15	.BOLT,HEX.HD		4
11	XBOZZ	92021	SP-17-16	.NUT,HEX 1/2-13		4
12	XDOZZ	92022	1SP-17-20	.WASHER,LOCK		4
13	XAOZZ	92021	SP-17-3	.END FITTING		2
14	XDOZZ	92021	SP-17-13	.PACKING,PREFORMED		2
15	XDOZZ	92021	SP-17-8B	.SEAT		2
16	XAOZZ	92021	SP-17-2	.BALL		1
17	XDOZZ	92021	SP-17-2	.BODY		1
18	PAOZZ	96906	MS27022-11	COUPLING HALF,QUICK		3
19	PAOZO	96906	MS27026-11	COUPLING HALF,QUICK		2
20	PAOZZ	96906	MS27030-6	.GASKET		1

END OF FIGURE

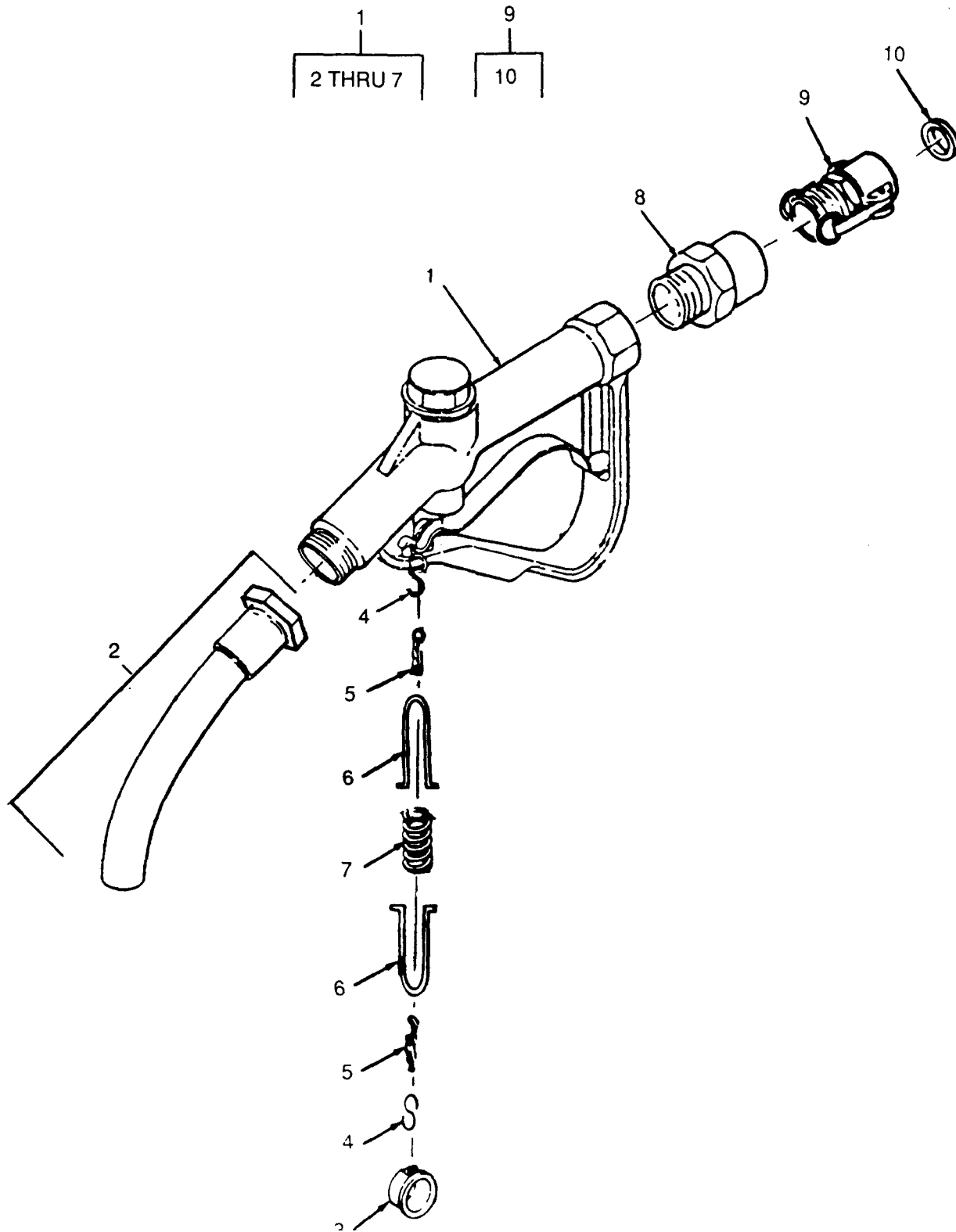
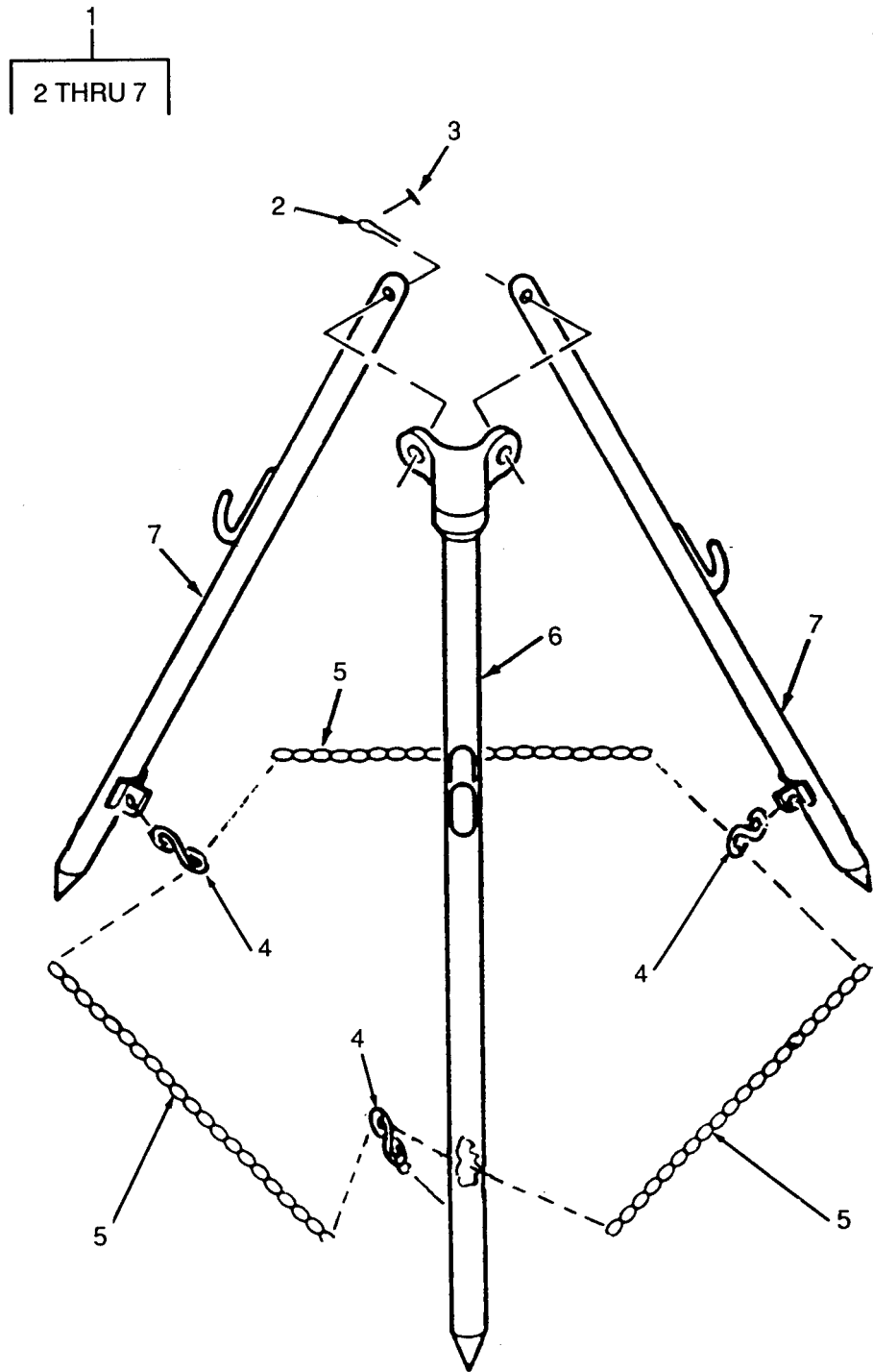

Figure 2. Distribution Nozzle, Potable Water.

SECTION II		TM5-4320-301-13&P			
(1)	(2)	(3)	(4)	(5)	(6)
ITEM	SMR		PART		
NO	CODE	CAGEC	NUMBER	DESCRIPTION AND USABLE ON CODES (UOC)	QTY
				GROUP 02 NOZZLE DISTRIBUTION ASSEMBLY	
				FIG. 2 DISTRIBUTION NOZZLE, POTABLE WATER	
1	PAOZZ	97403	13225E9094-2	NOZZLE, WATER DISTRI	4
2	XDOZZ	81718	C-3304	.SPOUT ASSY	1
3	XDOZZ	81718	H-9116-AT	.CAP, DUST	1
4	XDOZZ	81718	H-3283-M	.LINKS, S	2
5	XDOZZ	81718	H-9112-RS	.CHAIN	2
6	XDOZZ	81718	H-9210-M	.DRAW BAR	2
7	XDOZZ	81718	H-9209-M	.SPRING, COMPRESSION	1
8	PBOZZ	97403	13225E9138-1	SWIVEL JOINT, PIPE	1
9	PBOZZ	96906	MS49002-17	COUPLING HALF, QUICK	1
10	PAOZZ	96906	MS27030-5	.GASKET	1
				END OF FIGURE	



SECTION II		TM5-4320-301-13&P			
(1)	(2)	(3)	(4)	(5)	(6)
ITEM	SMR		PART		
NO	CODE	CAGEC	NUMBER	DESCRIPTION AND USABLE ON CODES (UOC)	QTY
				GROUP 03 STAND ASSEMBLY	
				FIG. 3 NOZZLE STAND ASSEMBLY	
1	PBOOF	97403	13225E9140	STAND ASSY,FUEL	2
2	PBOZZ	96906	MS24665-134	.PIN,COTTER	2
3	PBOZZ	96906	MS20392-3C35	.PIN,STRAIGHT,HEADED	2
4	PBOZZ	96906	MS87006-33	.HOOK,CHAIN,S	3
5	MOOOO	97403	13225E9140/3	.CHAIN MAKE FROM P/N RR-C-271, TR 35, TYPE II, CL 3, 45 LINKS	3
6	XDOZZ	97403	13225E9145	.LEG,PIVOT	1
7	XDOZZ	97403	13225E9146	.LEG,CLEVIS	2
				END OF FIGURE	

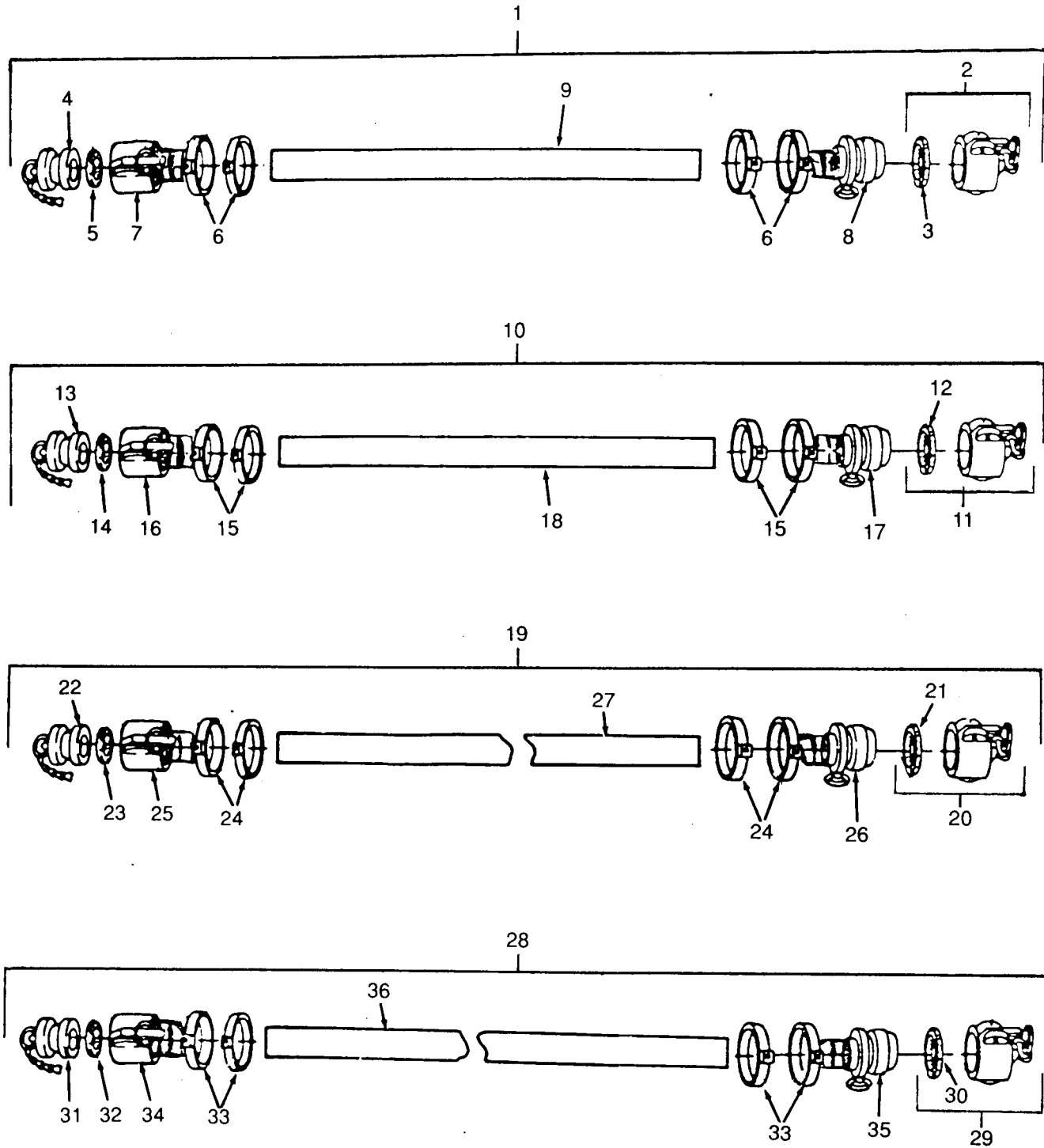
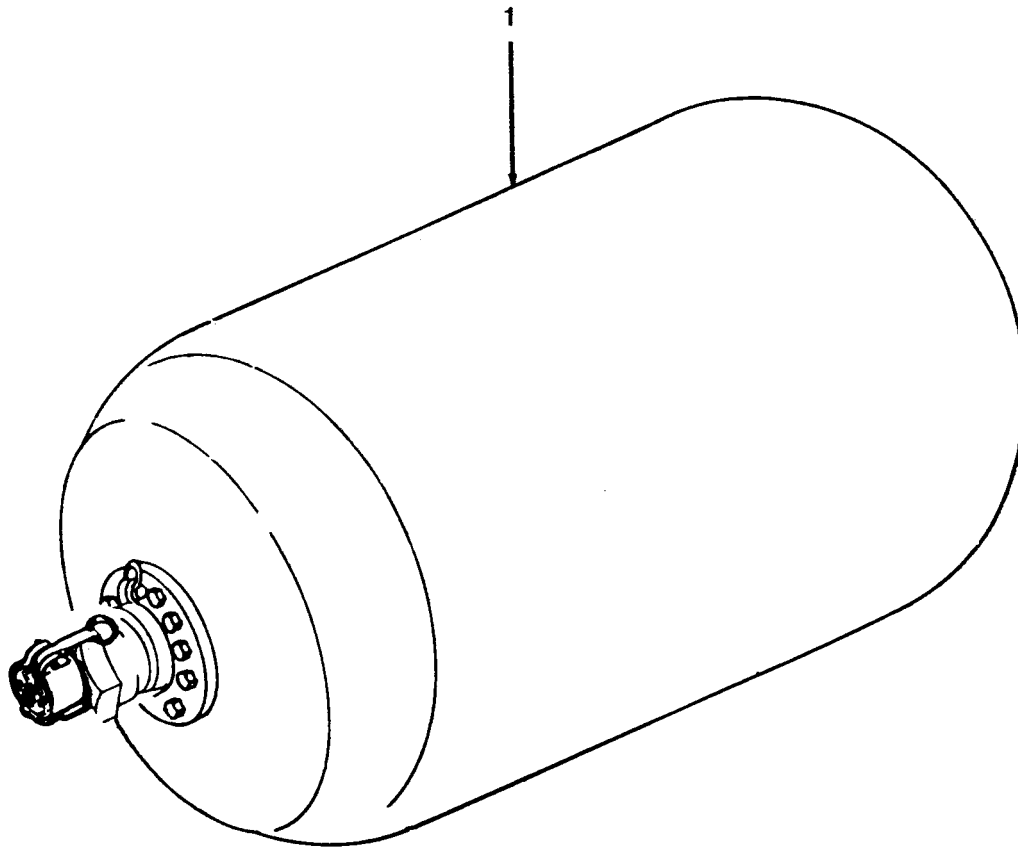

Figure 4. Hose Assemblies, Potable Water.

SECTION II					
(1) ITEM NO	(2) SMR CODE	(3) CAGEC	(4) PART NUMBER	(5) DESCRIPTION AND USABLE ON CODES (UOC)	(6) QTY
<b>GROUP 04 HOSE ASSEMBLY</b>					
<b>FIG. 4 HOSE ASSEMBLIES, POTABLE WATER</b>					
1	PAOZZ	97403	13225E9135-1	HOSE ASSEMBLY, NONME SUCTION, 2 IN X 10 FT LG.....	3
2	PAOZZ	96906	MS27028-11	.CAP, QUICK DISCONN.....	1
3	PAOZZ	96906	MS27030-6	..GASKET .....	1
4	PAOZZ	96906	MS27029-11	.PLUG, QUICK DISCONN.....	1
5	PAOZZ	96906	MS27030-6	.GASKET .....	1
6	XDOZZ	70847	1230	.CLAMP, HOSE .....	4
7	XDOZO	96906	MS2702511	.COUPLING HALF, QUICK.....	1
8	XDOZZ	96906	MS27021-11	.COUPLING HALF, QUICK.....	1
9	MOOOO	97403	13225E9135	.HOSE, RUBBER MAKE FROM P/N ZZ-H-561, GR A, CL 2, 2 IN., 10 F T. LONG .....	1
10	PAOOO	97403	13225E9136-1	HOSE ASSEMBLY, NONME DISCHARGE, 2 IN X 10 FT LG.....	1
11	PAOZZ	96906	MS27028-11	.CAP, QUICK DISCONN.....	1
12	PAOZZ	96906	MS27030-6	..GASKET .....	1
13	PAOZZ	96906	MS27029-11	.PLUG, QUICK DISCONN.....	1
14	PAOZZ	96906	MS27030-6	.GASKET .....	1
15	XDOZZ	70847	1230	.CLAMP, HOSE .....	4
16	XDOZO	96906	MS27025-11	.COUPLING HALF, QUICK.....	1
17	XDOZZ	96906	MS27021-11	.COUPLING HALF, QUICK.....	1
18	MOOOO	97403	13225E9136-1/10F	.HOSE, RUBBER MAKE FROM P/N ZZ-H-601, GR 3, CL 2, 2 IN., 10 FT. LONG .....	1
19	PAOOO	97403	13225E9136-5	HOSE ASSEMBLY, NONME DISCHARGE, 2 IN X 25 FT LG .....	2
20	PAOZZ	96906	MS27028-11	.CAP, QUICK DISCONN.....	1
21	PAOZZ	96906	MS27030-6	..GASKET .....	1
22	PAOZZ	96906	MS27029-11	.PLUG, QUICK DISCONN.....	1
23	PAOZZ	96906	MS27030-6	.GASKET .....	1
24	XDOZZ	70847	1230	.CLAMP, HOSE .....	4
25	XDOZO	96906	MS27025-11	.COUPLING HALF, QUICK.....	1
26	XDOZZ	96906	MS27021-11	.COUPLING HALF, QUICK.....	1
27	MOOZZ	81348	13226E9136-5/25F	.HOSE, RUBBER MAKE FROM P/N ZZ-H-601, GR 3, CL 2, 2 IN., 25 FT LONG .....	1
28	PAOOZ	97403	13225E9136-11	HOSE ASSEMBLY, NONME DISCHARGE, 1-1/2 IN X 25 FT LG.....	4
29	PAOZZ	96906	MS27028-9	.CAP, QUICK DISCONN.....	1
30	PAOZZ	96906	MS27030-5	..GASKET .....	1
31	PAOZZ	96906	MS27029-9	.PLUG, QUICK DISCONN.....	4
32	PAOZZ	96906	MS27030-5	.GASKET .....	1
33	XDOZZ	70847	1208	.CLAMP, HOSE .....	4
34	XDOZO	96906	MS27025-9	.COUPLING HALF, QUICK.....	1
35	XDOZZ	96906	MS27021-9	.COUPLING HALF, QUICK.....	1
36	MOOOO	97403	13225E9136-11/6	.HOSE, RUBBER MAKE FROM P/N ZZ-H-601, GR 3, CL 2, 1 1/2 IN., 25 FT. LONG .....	1

END OF FIGURE





SECTION II		TM5-4320-301-13&P			
(1)	(2)	(3)	(4)	(5)	(6)
ITEM	SMR		PART		
NO	CODE	CAGEC	NUMBER	DESCRIPTION AND USABLE ON CODES (UOC)	QTY
				GROUP 05 WATER DRUM ASSEMBLY	
				FIG. 5 WATER FABRIC DRUM	
1	PDOFF	81349	MILD43699 SIZE 2	DRUM,FABRIC,COLLAPS (SEE TM10-8110-202-13&P FOR PARTS BREAKDOWN)	6
				END OF FIGURE	

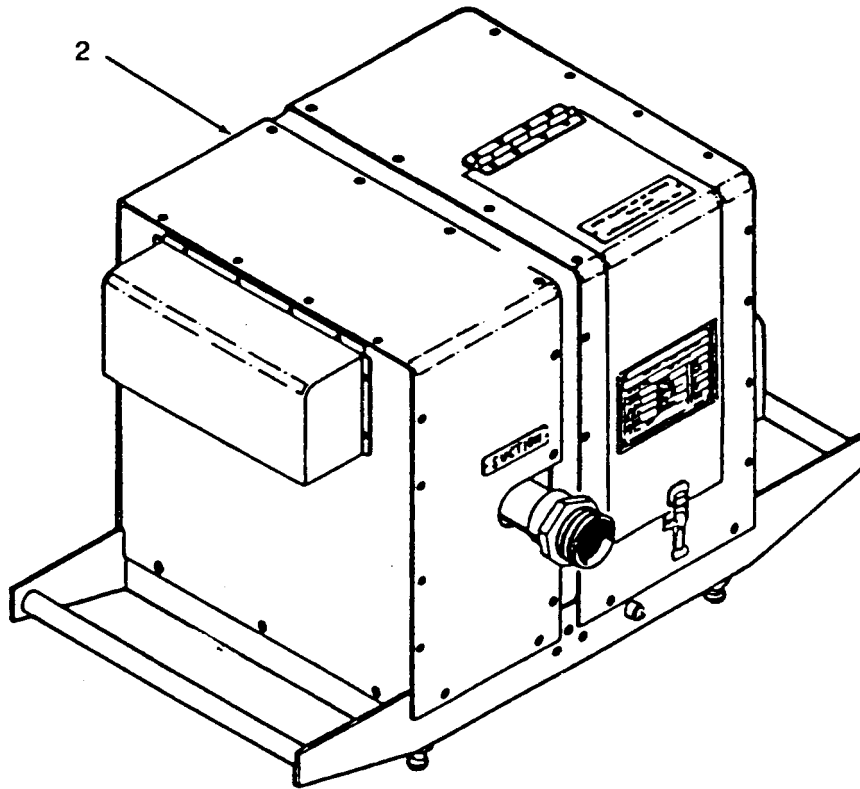
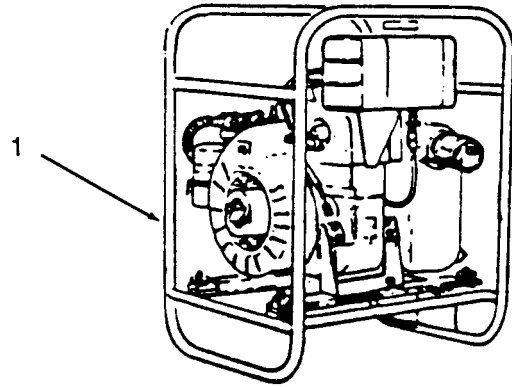

SECTION II		TM5-4320-301-13&P			
(1)	(2)	(3)	(4)	(5)	(6)
ITEM	SMR		PART		
NO	CODE	CAGEC	NUMBER	DESCRIPTION AND USABLE ON CODES (UOC)	QTY
				GROUP 06 PUMP ASSEMBLY	
				FIG. 6 CENTRIFUGAL PUMPS	
1	PDOHH	97403	2-125-50-G	PUMP UNIT,CENTRIFUG (SEE TM5-4320-208-12&P FOR PARTS BREAKDOWN) UOC:DVK	1
2	PDOHH	76371	PAD125A	PUMP UNIT,CENTRIFUG (SEE TM5-4320-309-24P FOR PARTS BREAKDOWN) UOC:FAL	1
				END OF FIGURE	

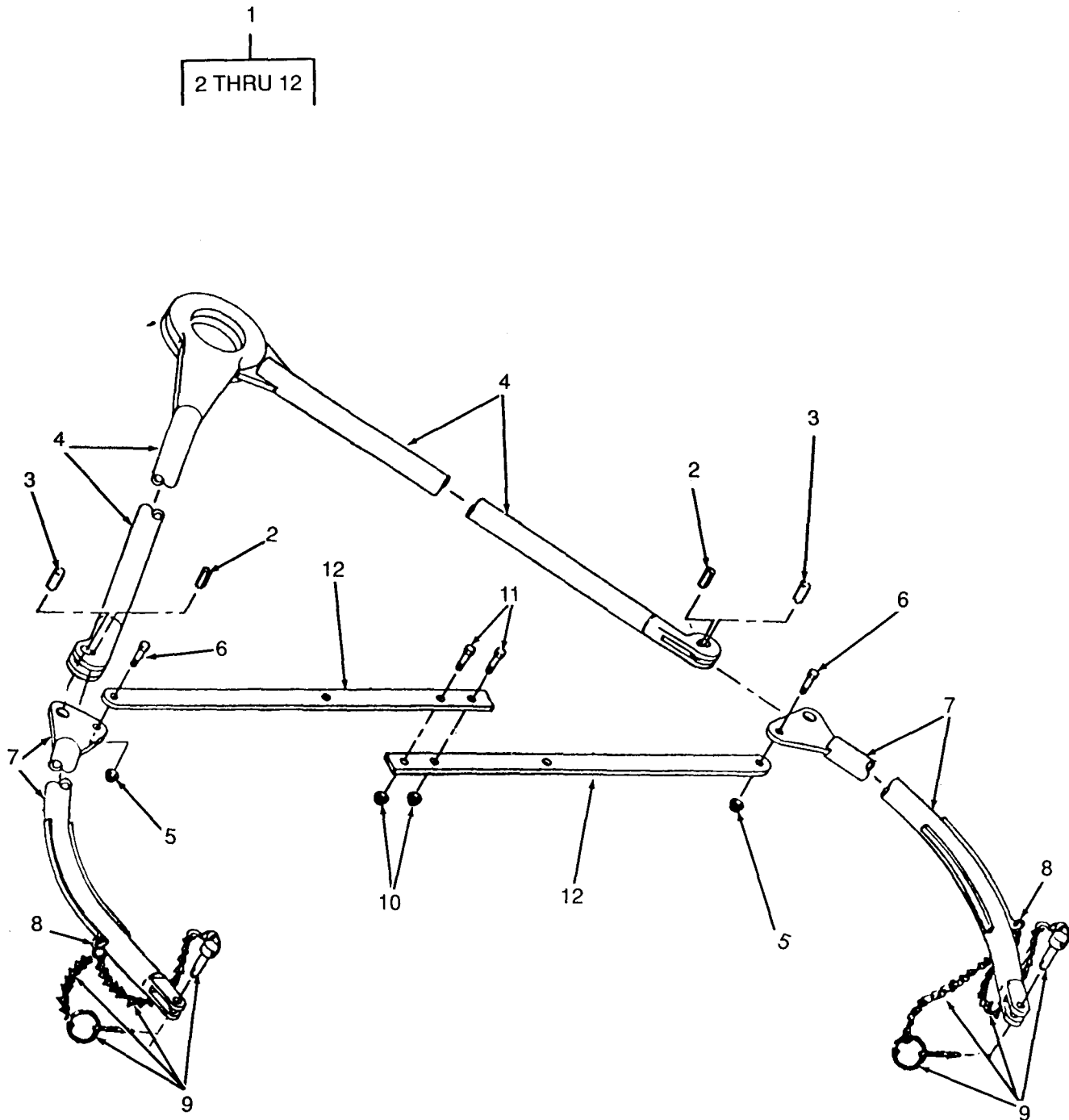

Figure 7. Towing and Lifting Yoke Assembly.

SECTION II		TM5-4320-301-13&P			
(1)	(2)	(3)	(4)	(5)	(6)
ITEM	SMR		PART		
NO	CODE	CAGEC	NUMBER	DESCRIPTION AND USABLE ON CODES (UOC)	QTY
GROUP 07 TOWING AND LIFTING YOKE ASSEMBLY					
FIG. 7 TOWING AND LIFTING YOKE ASSEMBLY					
1	PBOOO	97403	13216E7991	YOKE, TOWING AND LIF	1
2	PAOZZ	96906	MS51963-63	.SETScrew 0.25-20 X 0.25	2
3	XBOZZ	97403	13216E7995	.PIN, STRAIGHT, HEADLE	2
4	XBOZZ	97403	13216E7993	.LEG, UPPER	2
5	PAOZZ	96906	MS16228-10C	.NUT, SELF-LOCKING, HE 0.625-11	2
6	PAOZZ	96906	MS35307-463	.SCREW, CAP, HEXAGON H 0.625-11 X 1.75	2
7	XBOZZ	97403	13216E7992	.LEG, CONNECTING	2
8	PBOZZ	96906	MS87006-33	.HOOK, CHAIN, S	2
9	PBOZO	97403	13216E8075	.CLEVIS PIN ASSEMBLY	2
10	PAOZZ	96906	MS16228-8C	.NUT, SELF-LOCKING, HE 0.5-13	2
11	PAOZZ	96906	MS35307-414	.SCREW, CAP, HEXAGON H 0.5-13 X 1.75	2
12	XBOZZ	97403	13216E7994	.BRACE	2
END OF FIGURE					

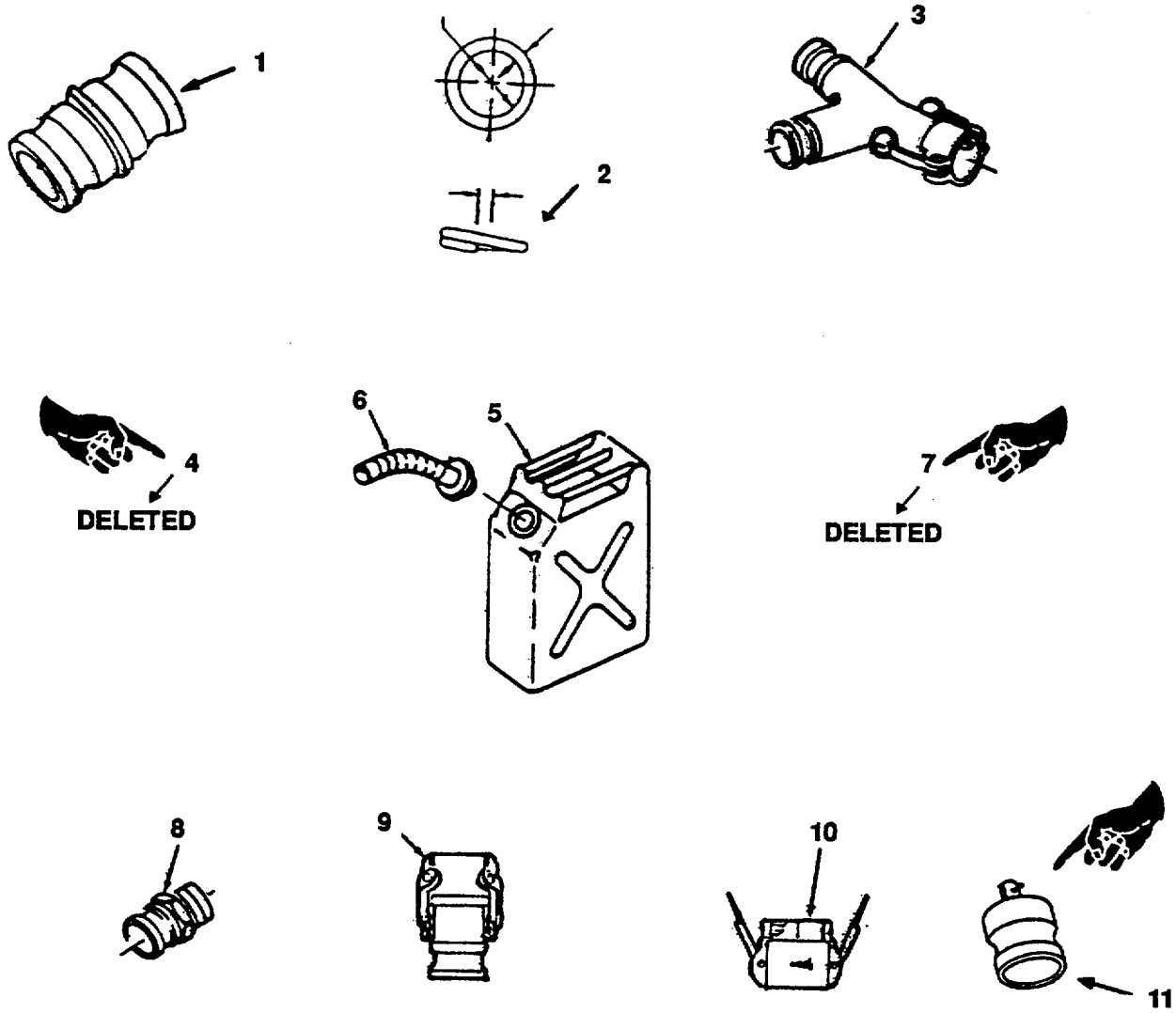

Figure 8. Miscellaneous Parts and Fittings.

SECTION II					
(1) ITEM NO	(2) SMR CODE	(3) CAGEC	(4) PART NUMBER	(5) DESCRIPTION AND USABLE ON CODES (UOC)	(6) QTY
<b>GROUP 08 MISCELLANEOUS ITEMS</b>					
<b>FIG. 8 MISCELLANEOUS PARTS AND FITTINGS</b>					
1	PAOZZ	96906	MS39352-9	NIPPLE, QUICK-DISCON 2 IN MALE X 2 IN MALE .....	1
2	PBOZZ	81718	H1434M	RING, RETAINING.....	10
3	PBOZZ	97403	13219E0477	WYE, QUICK DISCONNEC .....	4
4	DELETED				
5	PBOZZ	81902	14196P1	CAN, GASOLINE, MILITA.....	2
6	PBOZZ	09647	838A7511	SPOUT, CAN, FLEXIBLE .....	1
7	DELETED				
8	XDOZZ	96906	MS51846-152	NIPPLE, PIPE 2 IN X 2 IN BRASS.....	1
9	PBOZZ	96906	MS49000-5	REDUCER, QUICK DISCO 2 IN FEMALE X 1-1/2 IN MALE .....	4
10	PAOZZ	96906	MS27024-11	COUPLING HALF, QUICK.....	1
11	PAOZZ	96906	MS27029-9	PLUG, QUICK DISCONNECT .....	4

END OF FIGURE

Change 8 C-23/(C-24 blank)





SECTION II		TM5-4320-301-13&P			
(1)	(2)	(3)	(4)	(5)	(6)
ITEM	SMR		PART		
NO	CODE	CAGEC	NUMBER	DESCRIPTION AND USABLE ON CODES (UOC)	QTY
				GROUP 09 BULK MATERIALS	
				FIG. BULK	
1	PBOZZ	81348	RR-C-271,TR35,TY PEII,CL3	CHAIN	3
2	PBOZZ	81349	ZZ-H-561,GRA,CL 2,2 IN X 10 FT	HOSE	1
3	PBOZZ	81348	ZZ-H-601,GR3,CL 2,2 IN	HOSE,RUBBER	1
4	PAOZZ	81348	ZZ-H-601,GR3,CL 2,1 1/2"X25'	HOSE, RUBBER	1
				END OF FIGURE	

SECTION IV

CROSS- REFERENCE-INDEXES  
 NATIONAL STOCK NUMBER INDEX

STOCK NUMBER	FIG.	ITEM	STOCK NUMBER	FIG.	ITEM
DELETED	C-8	7	4720-01-174-8173	C-4	28
4730-00-088-9285	C-1	19	4720-01-175-5957	C-4	19
7240-00-177-6154	C-8	6	2910-01-188-8197	C-2	1
7240-00-222-3088	C-8	5	4730-01-189-1233	C-2	8
5310-00-241-6667	C-7	10	4320-01-247-7127	C-6	2
5310-00-245-8826	C-7	5	5315-01-258-6496	C-7	9
4820-00-330-5466	C-1	1			
5330-00-360-0595	C-2	10			
	C-4	30			
	C-4	32			
4320-00-542-3347	C-6	1			
5330-0-612-2414	C-1	20			
	C-4	3			
	C-4	5			
	C-4	12			
	C-4	14			
	C-4	21			
	C-4	23			
4730-00-649-9100	C-4	2			
	C-4	11			
	C-4	20			
4730-00-649-9103	C-8	10			
5305-00-723-9387	C-7	2			
5305-00-727-6804	C-7	11			
5315-00-812-1236	C-3	3			
4730-00-823-5316	C-4	31			
	C-8	11			
5315-00-839-5820	C-3	2			
8110-856-6243	C-7	1			
4730-00-869-5246	C-4	29			
4730-00-915-5127	C-4	4			
	C-4	13			
	C-4	22			
5365-0-926-5411	C-8	2			
47304)0-938-7997	C-1	18			
5305-00-941-3579	C-7	6			
4030-00-948-7315	C-3	4			
	C-7	8			
4730-00-951-3295	C-8	9			
4730-01-009-1735	C-8	1			
4730-01-068-5070	C-8	3			
DELETED	C-8	4			
4930-01-120-7426	C-3	1			
8110-01-122-0015	C-5	1			
4730-01-126-3825	C-2	9			
4720-01-163-4683	C-4	1			
4720-01-163-5088	C-4	10			

SECTION IV

CROSS-REFERENCE INDEXES  
PART NUMBER INDEX

CAGEC	PART NUMBER	STOCK NUMBER	FIG.	ITEM
81718	C-3304		C-2	2
81718	H-3283-M		C-2	4
81718	H-9112-RS		C-2	5
81718	H9116-AT		C-2	3
81718	H-9209-M		C-2	7
81718	H-9210-M		C-2	6
81718	H1434M	5365-00-926-5411	C-8	2
81349	MILD43699 SIZE 2	8110-01-122-0015	C-5	1
96906	MS16228-1OC	5310-00-245-8826	C-7	5
96906	MS16228-8C	5310-00-241-6667	C-7	10
96906	MS20392-3C35	5315-00-812-1236	C-3	3
96906	MS24665-134	5315-00-839-5820	C-3	2
96906	MS27021-11		C-4	8
			C-4	17
			C-4	26
96906	MS27021-9		C-4	35
96906	MS27022-11	4730-00-938-7997	C-1	18
96906	MS27024-11	4730-00-649-9103	C-8	10
96906	MS27025-11		C-4	7
			C-4	16
			C-4	25
96906	MS27025-9		C-4	34
96906	MS27026-11	4730-00-088-9285	C-1	19
96906	MS27028-11	4730-00-649-9100	C-4	2
			C-4	11
			C-4	20
96906	MS27028-9	4730-00-869-5246	C-4	29
96906	MS27029-11	4730-00-915-5127	C-4	4
			C-4	13
			C-4	22
96906	MS27029-9	4730-00-823-5316	C-4	31
			C-8	11
96906	MS27030-5	5330-00-360-0595	C-2	10
			C-4	30
			C-4	32
96906	MS27030-6	5330-00-612-2414	C-1	20
			C-4	3
			C-4	5
			C-4	12
			C-4	14
			C-4	21
			C-4	23
96906	MS35307-414	5305-00-727-6804	C-7	11
96906	MS35307-463	530540-941-3579	C-7	6
96906	MS39352-9	4730-01A0cO1735	C-8	1
96906	MS49000-5	4730-00-951-3295	C8	9
96906	MS49002-17	4730-01-126-3825	C-2	9

SECTION IV

CROSS-REFERENCE INDEXES  
 PART NUMBER INDEX

CAGEC	PART NUMBER	STOCK NUMBER	FIG.	ITEM
96906	MS51846-152	4730-222-1844	C-8	8
96906	MS51963-63	5305-00-723-9387	C-7	2
96906	MS87006-33	4030-00-948-7315	C-3	4
			C-7	8
76371	PAD125A	4320-01-247-7127	C-6	2
81348	RR-C-271,TR35, TYPEII, CL3		BULK	1
92021	SP-17-10		C-1	7
92021	SP-17-13		C-1	14
92021	SP-17-15		C-1	10
92021	SP-17-16		C-1	11
92021	SP-17-17		C-1	2
92021	SP-1 7-2		C-1	16
			C-1	17
92021	SP-17-21		C-1	9
92021	SP-1 7-3		C-1	13
92021	SP-1 7-4		C-1	4
92021	SP-17-44		C-1	3
92021	SP-1 7-5A		C-1	6
92021	SP-17-6		C-1	5
92021	SP-17-8B		C-1	15
92021	SP-17-9		C-1	8
81349	ZZ-H-561,GRA,CL2,21N X 10 FT		BULK	2
81348	ZZ-H-601 ,GR3,CL2,1 1/2" X25'		BULK	4
81348	ZZ-H-601 ,GR3,CL2, 2 IN		BULK	3
92022	1 SP-1 7-20		C-1	12
70847	1208		C-4	33
70847	1230		C-4	6
			C-4	15
			C-4	24
	DELETED		C-8	4
	DELETED		C-8	7
97403	13216E7991	8110-00-856-6243	C-7	1
97403	13216E7992		C-7	7
97403	13216E7993		C-7	4
97403	13216E7994		C-7	12
97403	13216E7995		C-7	3
97403	13216E8075	5315-01-258-6496	C-7	9
97403	13219E0477	4730-01-068-5070	C-8	3
97403	13225E9094-2	2910-01-188-8197	C-2	1
97403	13225E9135		C-4	9
97403	13225E9135-1	4720-01-163-4683	C-4	1
97403	13225E9136-1	4720-01-163-5088	C-4	10
97403	13225E9136-1/1 OF		C-4	18
97403	13225E9136-11	4720-01-174-8173	C-4	28
97403	13225E9136-11/6		C-4	36
97403	13225E9136-5	4720-01-175-5957	C-4	1
97403	13225E9137-2	4820-00-330-5466	C-1	1

SECTION IV

CROSS-REFERENCE INDEXES  
PART NUMBER INDEX

CAGEC	PART NUMBER	STOCK NUMBER	FIG.	ITEM
97403	13225E9138-1	4730-01-189-1233	C-2	8
97403	13225E91 40	4930-01-120-7426	C-3	1
97403	13225E9140/3		C-3	5
97403	13225E9145		C-3	6
97403	13225E9146		C-3	7
81348	13226E9136-5/25F		C-4	27
81902	14196P1	7240-00-222-3088	C-8	5
97403	2-125-50-G	4320-00-542-3347	C-6	1
09647	838A7511	7240-00-177-6154	C-8	6

Change 8 C-29

SECTION IV

CROSS-REFERENCE INDEXES

FIG.	FIGURE AND ITEM	INDEX STOCK NUMBER	CAGEC	PART NUMBER
BULK	1		81348	RR-C-271, TR35, TY PEII, CL3
BULK	2		81349	ZZ-H-561, GRA, CL 2, 2 IN X 10 FT
BULK	3		81348	ZZ-H-601, GR3, CL 2, 2 IN
BULK	4		81348	ZZ-H-601, GR3, CL 2, 1 1/2" X 25'
C-1	1	4820-00-330-5466	97403	13225E9137-2
C-1	2		92021	SP-17-17
C-1	3		92021	SP-17-44
C-1	4		92021	SP-17-4
C-1	5		92021	SP-17-6
C-1	6		92021	SP-17-5A
C-1	7		92021	SP-17-10
C-1	8		92021	SP-17-9
C-1	9		92021	SP-17-21
C-1	10		92021	SP-17-15
C-1	11		92021	SP-17-16
C-1	12		92022	1SP-17-20
C-1	13		92021	SP-17-3
C-1	14		92021	SP-17-13
C-1	15		92021	SP-17-8B
C-1	16		92021	SP-17-2
C-1	17		92021	SP-17-2
C-1	18	4730-00-938-7997	96906	MS27022-11
C-1	19	4730-00-088-9285	96906	MS27026-11
C-1	20	5330-00-612-2414	96906	MS27030-6
C-2	1	2910-01-188-8197	97403	13225E9094-2
C-2	2		81718	C-3304
C-2	3		81718	H-9116-AT
C-2	4		81718	H-3283-M
C-2	5		81718	H-9112-RS
C-2	6		81718	H-9210-M
C-2	7		81718	H-9209-M
C-2	8	4730-01-189-1233	97403	13225E9138-1
C-2	9	4730-01-126-3825	96906	MS49002-17
C-2	10	5330-00-360-0595	96906	MS27030-5
C-3	1	4930-01-120-7426	97403	13225E9140
C-3	2	5315-00-839-5820	96906	MS24665-134
C-3	3	5315-00-812-1236	96906	MS20392-3C35
C-3	4	4030-00-948-7315	96906	MS87006-33
C-3	5		97403	13225E9140/3
C-3	6		97403	13225E9145
C-3	7		97403	13225E9146
C-4	1	4720-01-163-4683	97403	13225E9135-1
C-4	2	4730-00-649-9100	96906	MS27028-11
C-4	3	5330-00-612-2414	96906	MS27030-6
C-4	4	4730-00-915-5127	96906	MS27029-11
C-4	5	5330-00-612-2414	96906	MS27030-6
C-4	6		70847	1230

SECTION IV

CROSS REFERENCE INDEXES

FIG.	ITEM	FIGURE AND ITEM NUMBER INDEX STOCK NUMBER	CAGEC	PART NUMBER
C-4	7		96906	MS27025-11
C-4	8		96906	MS27021-11
C-4	9		97403	13225E9135
C-4	10	4720-01-163-5088	97403	13225E9136-1
C-4	11	473040-649-9100	96906	MS27028-11
C-4	12	5330-00-612-2414	96906	MS27030-6
C-4	13	4730-00-915-5127	96906	MS27029-11
C-4	14	5330-00-612-2414	96906	MS27030-6
C-4	15		70847	1230
C-4	16		96906	MS27025-11
C-4	17		96906	MS27021-11
C-4	18		97403	13225E9136-1/10F
C-4	19	4720-01-175-5957	97403	13225E9136-5
C-4	20	4730-00-649-9100	96906	MS27028-11
C-4	21	5330-00-612-2414	96906	MS27030-6
C-4	22	4730-00-915-5127	96906	MS27029-11
C-4	23	5330-00-612-2414	96906	MS27030-6
C-4	24		70847	1230
C-4	25		96906	MS27025-11
C-4	26		96906	MS27021-11
C-4	27		81348	13226E9136-5/25F
C-4	28	4720-01-174-8173	97403	13225E9136-11
C-4	29	4730-00-869-5246	96906	MS27028-9
C-4	30	5330-00-360-0595	96906	MS27030-5
C-4	31	4730-00-823-5316	96906	MS27029-9
C-4	32	5330-360-0595	96906	MS27030-5
C-4	33		79847	1208
C-4	34		96906	MS27025-9
C-4	35		96906	MS27021-9
C-4	36		97403	13225E9136-11/6
C-5	1	8110-01-122-0015	81349	MILD43699 SIZE 2
C-6	1	4320-00-542-3347	97403	2-125-50-G
C-6	2	4320-01-247-7127	76371	PAD125A
C-7	1	8110-00-856-6243	97403	13216E7991
C-7	2	5305-00-723-9387	96906	MS51963-63
C-7	3		97403	13216E7995
C-7	4		97403	13216E7993
C-7	5	5310-00-245-8826	96906	MS16228-10C
C-7	6	5305-00-941-3579	96906	MS35307-463
C-7	7		97403	13216E7992
C-7	8	4030-00-948-7315	96906	MS87006-33
C-7	9	5315-01-258-6496	97403	13216E8075
C-7	10	5310-00-241 667	96906	MS16228-8C

SECTION IV

CROSS REFERENCE INDEXES

FIG.	ITEM	FIGURE AND ITEM NUMBER INDEX STOCK NUMBER	CAGEC	PART NUMBER
C-7	11	5305-00-727-6804	96906	MS35307-414
C-7	12		97403	13216E7994
C-8	1	4730-01-009-1735	96906	MS39352-9
C-8	2	5365-00-926-5411	81718	H1434M
C-8	3	4730-01-068-5070	97403	13219E0477
C-8	4	DELETED		
C-8	5	7240-00-222-3088	81902	14196P1
C-8	6	7240-00-177-6154	09647	838A7511
C-8	7	DELETED		
C-8	8	4730-00-222-1844	96906	MS51846-152
C-8	9	4730-00-951-3295	96906	MS49000-5
C-8	10	4730-00-649-9103	96906	MS27024-11
C-8	11	4730-00-823-5316	96906	MS27029-9

C-32 Change 8



## APPENDIX D EXPENDABLE SUPPLIES AND MATERIALS LIST

### Section I INTRODUCTION

D-1. **SCOPE.** This appendix lists expendable supplies and materials you will need to operate and maintain the FAWPSS System.

#### D-2. EXPLANATION OF COLUMNS.

*a. Column 1, Item Number.* This number is assigned to the entry in the listing and is referenced in the narrative instructions to identify the material (e.g., "Use cleaning compound, item 5, APPL E).

*b. Column 2, Level.* This column identifies the lowest level of maintenance that requires the listed item.

- C - Operator/Crew
- O - Organizational Maintenance
- F - Direct Support Maintenance
- H - General Support Maintenance

*c. Column 3, National Stock Number.* This is the National stock number assigned to the item; use it to request or requisition the item.

*d. Column 4, Description.* Indicates the Federal item name and, if required, a description to identify the item. The last line for each item indicates the part number followed by the Federal Supply Code for Manufacturer (FSCM) in parentheses, if applicable.

*e. Column 5, Unit of Measure (U/M).* Indicates the measure used in performing the actual maintenance function. This measure is expressed by a two-character alphabetical abbreviation (e.g., ea., in., pr.). If the unit of measure differs from the unit of issue, requisition the lowest unit of issue that will satisfy your requirements.

Section II  
EXPENDABLE SUPPLIES AND MATERIALS

ITEM NO.	LEVEL	NATIONAL STOCK NUMBER	DESCRIPTION	U/M
1	C	5120-00-278-9925	Clamping Tool	ea
2	O	7920-00-205-1711	Cloth, Lint-Free	ea
3	C	8030-00-889-3535	Tap	ea
4	C	6850-00-664-5685	Dry Cleaning Solvent A-A-711, Type I	gl
5	O	8020-00-207-6658	Brush, Medium, Oval	ea
6	O	7930-00-068-1669	Detergent, General Purpose	gl

D-2 Change 8

## APPENDIX E

**Table E-1. SELF-LOCKING NUT BREAKAWAY TORQUE LIMITS**

Thread Size	Minimum Breakaway Torque (IN. -LBS)	Thread Size	Minimum Breakaway Torque (IN. -LBS)
10-32	2.0	5/8-18	32.0
1/4-28	3.5	3/4-16	50.0
5/16-24	6.5	7/8-14	70.0
3/8-24	9.5	1-12	90.0
7/16-20	14.0	1-1/8-12	117.00
9/16-18	24.0		

### NOTE

To determine breakaway torque, thread into screw or bolt until at least two threads stick out. Nut shall not make contact with a mating part. Stop the nut. Torque necessary to begin turning nut again is the breakaway torque. Do not reuse self-locking nuts that do not meet minimum breakaway torque.



## APPENDIX F. COMPONENTS OF END ITEM AND BASIC ISSUE ITEMS LISTS

---

### Section I. INTRODUCTION

#### F-1. SCOPE.

This appendix components of the end item and basic issue items for the FAWPSS to help you inventory the items for safe and efficient operation.

#### F-2. GENERAL.

The Components of End Item and Basic Issue Items Lists are divided into the following sections:

*a. Section II, components of End Items.* This listing is for informational purposes only, and is not authority to requisition replacements. These items are part of the end item, but they are removed and separately packaged for transportation or shipment. As part of the end item, these items must be with the end item whenever it is issued or transferred between property accounts. Illustrations are furnished to assist you in identifying the items.

*b. Section III, Basic Issue Items. (NOT APPLICABLE)*

#### F-3. EXPLANATION OF COLUMNS.

The following provides an explanation of columns found in the tabular listing:

*a Column (1) - Illustrations Number (Illus Number).* This column indicates the number of the illustration in which the item is shown.

*b. Column (2) - National Stock Number.* Indicates the National stock number assigned to the item and will be used for requisitioning purposes.

*c. column (3) - Description.* Indicates the Federal item name and, if required, a minimum description to identify and locate the item. The last line for each item indicates the CAGE (in parentheses) followed by the part number.

*d. Column (4) - Unit of Measure (U/M).* indicates The measure used in performing the actual operational/maintenance function. This measure is expressed by a two-character alphabetical abbreviation (e.g., ea, in pr).

*e. Column (5) - Quantity required (Qty rqr)-* Indicates the quantity of the item authorized to be used with/on the equipment.

Section II. COMPONENTS OF END ITEM LIST

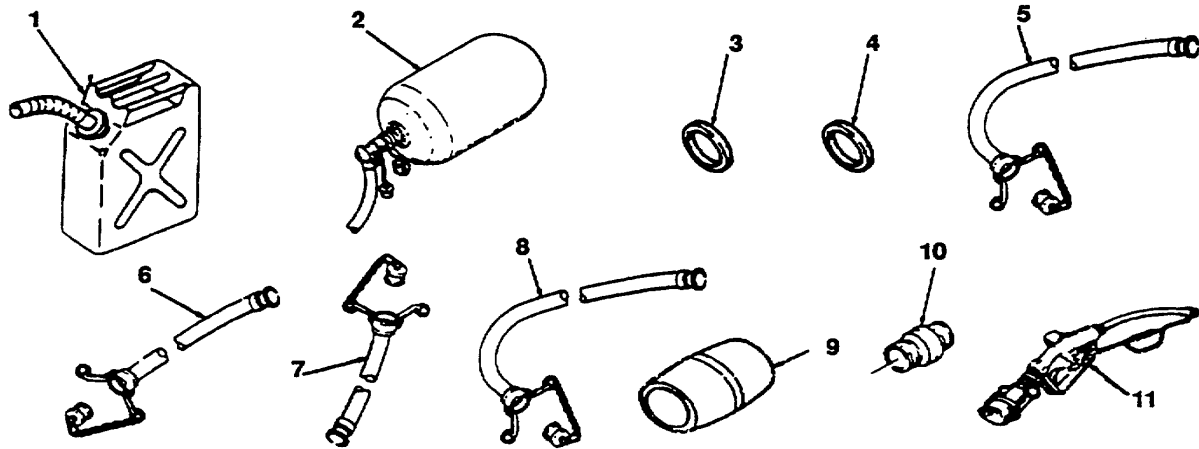

(1) ILLUS NUMBER	(2) NATIONAL STOCK NUMBER	(3) DESCRIPTION, CAGEC and Part Number	(4) Usable On Code U/M	(5) QTY Reqd
1	7240-00-222-3088	Can, 5-Gallon Gasoline	EA	2
2	8110-01-122-0015	Drum, Water, 500 Gallon (Collapsible Fabric Drum, 2-inch Elbow Coupler Valve Assembly)	EA	6
3	5330-00-360-0595	Gasket, Rubber, 1 1/2 Inch (96906) MS27030-5	EA	4
4	5330-00-612-2414	Gasket, Rubber, 2 Inch (96906) MS27030-6	EA	19
5	4720-01-174-8173	Hose Assembly, Discharge 1 1/2 Inch by 25 foot (97403) 13225E9136-11	EA	4
6	4720-01-163-5088	Hose Assembly, Discharge 2 Inch by 10 foot (97403) 13225E9136-1	EA	1
7	4720-01-175-5957	Hose Assembly, Discharge 2 Inch by 25 foot (97403) 13225E9136-5	EA	2
8	4720-01-163-4683	Hose Assembly, Suction, 2-Inch by 10 foot (97403) 13225E9135-1	EA	3
9	4730-00-222-1844	Nipple, Pipe (96906) MS51846-152	EA	1
10	4730-00-009-1735	Nipple Quick Disconnect (96906) MS39352-9	EA	1
11	4610-01-188-8197	Nozzle, Assembly, Water Distribution (81718) 811-PW Consisting of: -Distribution Nozzle -Swivel -Reducer, External pipe thread by quick-disconnect, cam locking type	EA	4

Section II. COMPONENTS OF END ITEM LIST (Con't)

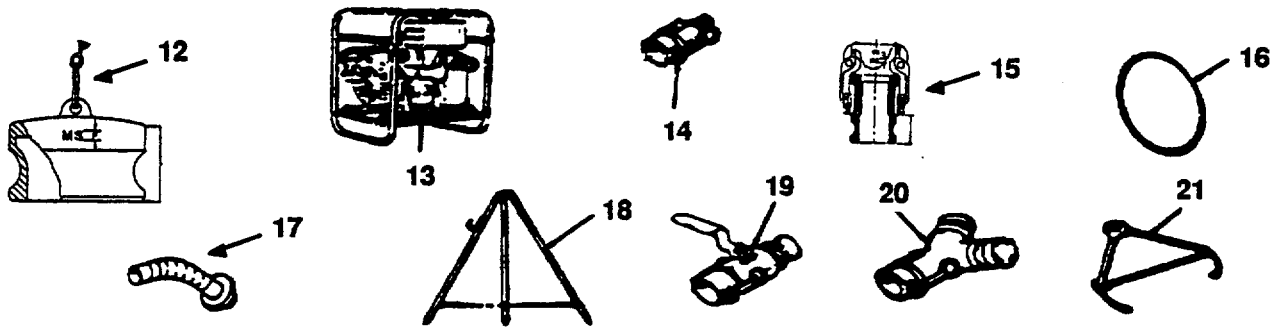

(1) ILLUS NUMBER	(2) NATIONAL STOCK NUMBER	(3) DESCRIPTION, CAGEC and Part Number	(4) Usable On Code U/M	(5) QTY Reqd
12	4730-00-823-5316	Plug, Quick Disconnect (96906) MS27029-9	EA	4
13	4320-00-542-3347	Pumping Assembly, 125 GPM (Quick Disconnect Male & Quick Disconnect Female). Used on FAWPSS Model WPSS100 only.	EA	1
	4320-01-247-7127	Pumping Assembly, 125 GPM (Quick Disconnect Male & Quick Disconnect Female). Used on FAWPSS Model 9095-91 only.	EA	1
	4320-01-190-0417	Pumping Assembly, 125 GPM; Used on Marine Corps Model Only.	EA	1
14	4730-01-126-3825	Reducer, Quick-Disconnect 1-1/2 Inch to 1 Inch (96906) MS49002-17	EA	4
15	4730-00-951-3295	Reducer, Quick Disconnect, 2 Inch Female to 1-1/2 Inch Male (96906) MS49000-5	EA	4
16	5365-00-926-5411	Ring Retaining (9H113) H01434M	EA	7
17	7240-00-177-6154	Spout, Can Flexible (81349) MIL-S-1285 (to be used with can, 5-gallon, gasoline)	EA	1
18	4930-01-120-7426	Stand Assembly (97403) 13225E9140	EA	2
19	4820-00-330-5466	Valve Assembly, 2-Inch (12168) T-590-Y-21NEA Consisting of: -Two-Inch Bronze/Aluminum Type-Threaded Ball Valve -Quick Disconnect Coupling Half, Cam Locking Type, Male -Quick Disconnect Coupling Half, Cam Locking Type, Female	EA 2	
20	4730-01-068-5070	Wye, Quick Disconnect, 2-Inch (97403) 13219E0477	EA	4
21	8110-00-856-6243	Yoke, Towing (97403)13216E7991	EA	1

Section III. BASIC ISSUE ITEMS LIST

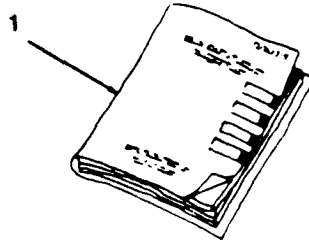

(1) Illus Number	(2) National Stock Number	Description CAGEC and Part Number	Usable On Code	(4) U/M	(5) Qty rq
1	4320-01-168-1629	TM5-4320-301-13&P		EA	



**INDEX**

Para./Table  
Number

- A -

Abbreviations ..... 1-6  
Assembly and preparation for Use ..... 2-5  
Assembly procedures ..... 2-8

- C -

Cross-References ..... 1-5  
Common Tools and Equipment ..... 4-3

- D -

Description and Operation ..... 1-12  
Destruction of Army Material to Prevent Enemy Use ..... 1-8  
Disassembly and Repackaging ..... 4-14

- E -

Equipment Description, Capabilities and Features ..... 1-9  
Equipment Data ..... 1-11

- G -

General Lubrication Instructions ..... 3-1

- H -

Hand Receipt ..... 1-3

- I -

Initial Adjustment ..... 2-7  
Inspection ..... 4-7

- L -

Location and Description of Major Components ..... 1-10  
Lubrication Instructions ..... 3-1

- M -

Maintenance Forms and Records ..... 1-2  
Maintenance Procedures ..... 3-3

- N -

Nomenclature, Cross-Reference List ..... 1-5

## INDEX (Cont'd.)

	Para./Table Number
- P -	
PMCS Procedures .....	2-4
Preparation for Storage or Shipment .....	1-9
- R -	
Repair Parts .....	4-5
Repair 2-Inch Valve Ashy .....	5-5
Repair Nozzle Distribution Assy .....	5-6
Reporting Equipment Improvement Recommendations (EIR) .....	1-4
- S -	
Special Tools, TMDE, and Support Equipment .....	4-4
System Controls and Indicators .....	2-2
- T -	
Troubleshooting Procedures .....	4-9
- U -	
Uncrating and Preparation For Use .....	4-1
- W -	
Water Systems Operation .....	2-9

**By Order of the Secretary of the Army:**

**JOHN A. WICKHAM, JR.**  
*General, United States Army*  
*Chief of Staff*

**Official:**

**MILDRED E. HEDBERG**  
*Brigadier General, United States Army*  
*The Adjutant General*

**DISTRIBUTION:**

To be distributed in accordance with DA Form 12-25A, Operator, Organizational, Direct Support and General Support Maintenance Requirements for Pump, Centrifugal, Frame Mounted, 125 GPM.

## These are the instructions for sending an electronic 2028

The following format must be used if submitting an electronic 2028. The subject line must be exactly the same and all fields must be included; however only the following fields are mandatory: 1, 3, 4, 5, 6, 7, 8, 9, 10, 13, 15, 16, 17, and 27.

From: "Whomever" <whomever@avma27.army.mil>  
To: mpmPtoavma28@st-louis-emh7.army.mil  
Subject: DA Form 2028

1. **From:** Joe Smith
2. **Unit:** home
3. **Address:** 4300 Park
4. **City:** Hometown
5. **St:** MO
6. **Zip:** 77777
7. **Date Sent:** 19-OCT-93
8. **Pub no:** 55-2840-229-23
9. **Pub Title:** TM
10. **Publication Date:** 04-JUL-85
11. **Change Number:** 7
12. **Submitter Rank:** MSG
13. **Submitter FName:** Joe
14. **Submitter MName:** T
15. **Submitter LName:** Smith
16. **Submitter Phone:** 123-123-1234
17. **Problem:** 1
18. **Page:** 2
19. **Paragraph:** 3
20. **Line:** 4
21. **NSN:** 5
22. **Reference:** 6
23. **Figure:** 7
24. **Table:** 8
25. **Item:** 9
26. **Total:** 123
27. **Text:**

This is the text for the problem below line 27.



THEN... JOT DOWN THE DOPE ABOUT IT ON THIS FORM. CAREFULLY TEAR IT OUT. FOLD IT AND DROP IT IN THE MAIL!

SOMETHING WRONG WITH THIS PUBLICATION?

FROM: (PRINT YOUR UNIT'S COMPLETE ADDRESS)  
**PFC JOHN DOE**  
**COA, 3d ENGINEER BN**  
**FT. LEONARD WOOD, MO 63108**  
 DATE SENT

PUBLICATION NUMBER: **TM 5-4320-301-13&P**  
 PUBLICATION DATE: **6 JAN 86**  
 PUBLICATION TITLE: **FORWARD AREA WATER POINT SUPPLY SYSTEM (FAWPSS) MODEL WPSS100 AND MODEL 9095-91**

BE EXACT. PIN-POINT WHERE IT IS				IN THIS SPACE TELL WHAT IS WRONG AND WHAT SHOULD BE DONE ABOUT IT:
PAGE NO	PARA-GRAPH	FIGURE NO	TABLE NO	
<b>6</b>	<b>2-1 a</b>			<i>In line 6 of paragraph 2-1a the manual states the engine has <u>6</u> cylinders. The engine on my set only has <u>4</u> cylinders. Change the manual to show <u>4</u> cylinders.</i>
<b>B1</b>		<b>4-3</b>		<i>Callout 16 on figure 4-3 is pointing at a <u>bolt</u>. In key to figure 4-3, item 16 is called a <u>shim</u>. Please correct one or the other.</i>
<b>125</b>	<b>line 20</b>			<i>I ordered a gasket, item 19 on figure B-16 by NSN 2 910-00-762-3001. I got a gasket but it doesn't fit. Supply says I got what I ordered, so the NSN is wrong. Please give me a good NSN</i>

TEAR ALONG PERFORATED LINE.

PRINTED NAME, GRADE OR TITLE, AND TELEPHONE NUMBER: **JOHN DOE, PFC (268) 317-7111**  
 SIGN HERE: **JOHN DOE**

DA FORM 2028-2 1 JUL 79

PREVIOUS EDITIONS ARE OBSOLETE.  
 DRSTS-M Overprint 1, 1 Nov 80

P.S.--IF YOUR OUTFIT WANTS TO KNOW ABOUT YOUR RECOMMENDATION MAKE A CARBON COPY OF THIS AND GIVE IT TO YOUR HEADQUARTERS.

1 Nov 80

FILL IN YOUR  
UNITS ADDRESS



FOLD BACK

DEPARTMENT OF THE ARMY

OFFICIAL BUSINESS

COMMANDER  
U.S. ARMY AVIATION AND TROOP COMMAND  
ATTN: AMSAT-I-MP  
4300 GOODFELLOW BOULEVARD  
ST. LOUIS, MO 63120-1798

TEAR ALONG PERFORATED LINE

RECOMMENDED CHANGES TO EQUIPMENT TECHNICAL PUBLICATIONS

**SOMETHING WRONG WITH THIS PUBLICATION?**



THEN... JOT DOWN THE DOPE ABOUT IT ON THIS FORM. CAREFULLY TEAR IT OUT. FOLD IT AND DROP IT IN THE MAIL!

FROM: (PRINT YOUR UNIT'S COMPLETE ADDRESS)

DATE SENT

PUBLICATION NUMBER

TM 5-4320-301-13&P

PUBLICATION DATE

6 JAN 86

PUBLICATION TITLE FORWARD AREA WATER POINT SUPPLY SYSTEM (FAWPSS) MODEL WSS100 AND MODEL 9095-91

BE EXACT. PIN-POINT WHERE IT IS

PAGE NO	PARA-GRAPH	FIGURE NO	TABLE NO
---------	------------	-----------	----------

IN THIS SPACE TELL WHAT IS WRONG AND WHAT SHOULD BE DONE ABOUT IT:

TEAR ALONG PERFORATED LINE

PRINTED NAME, GRADE OR TITLE, AND TELEPHONE NUMBER

SIGN HERE

DA FORM 2028-2  
1 JUL 79

PREVIOUS EDITIONS ARE OBSOLETE.  
DRSTS-M Overprint 2, 1 Nov 80.

P.S.--IF YOUR OUTFIT WANTS TO KNOW ABOUT YOUR RECOMMENDATION MAKE A CARBON COPY OF THIS AND GIVE IT TO YOUR HEADQUARTERS.

1 Nov 80

FILL IN YOUR  
UNITS ADDRESS



FOLD BACK

DEPARTMENT OF THE ARMY

---

---

OFFICIAL BUSINESS

COMMANDER  
U.S. ARMY AVIATION AND TROOP COMMAND  
ATTN: AMSAT-I-MP  
4300 GOODFELLOW BOULEVARD  
ST. LOUIS, MO 63120-1798

TEAR ALONG PERFORATED LINE



**SOMETHING WRONG WITH THIS PUBLICATION?**



THEN... JOT DOWN THE DOPE ABOUT IT ON THIS FORM. CAREFULLY TEAR IT OUT. FOLD IT AND DROP IT IN THE MAIL!

FROM: (PRINT YOUR UNIT'S COMPLETE ADDRESS)

DATE SENT

PUBLICATION NUMBER

PUBLICATION DATE

PUBLICATION TITLE FORWARD AREA WATER  
POINT SUPPLY SYSTEM (FAWPSS)  
MODEL WPSS100 AND MODEL 9095-91

TM 5-4320-301-13&P

6 JAN 86

BE EXACT... PIN-POINT WHERE IT IS

IN THIS SPACE TELL WHAT IS WRONG AND WHAT SHOULD BE DONE ABOUT IT:

PAGE  
NO

PARA-  
GRAPH

FIGURE  
NO

TABLE  
NO

TEAR ALONG PERFORATED LINE

PRINTED NAME, GRADE OR TITLE, AND TELEPHONE NUMBER

SIGN HERE.

**DA FORM 2028-2**  
1 JUL 79

PREVIOUS EDITIONS  
ARE OBSOLETE.  
DRSTS-M Overprint 2, 1 Nov 88.

P.S.--IF YOUR OUTFIT WANTS TO KNOW ABOUT YOUR  
RECOMMENDATION MAKE A CARBON COPY OF THIS  
AND GIVE IT TO YOUR HEADQUARTERS.

1 Nov 80

FILL IN YOUR  
UNITS ADDRESS



FOLD BACK

DEPARTMENT OF THE ARMY

OFFICIAL BUSINESS

COMMANDER  
U.S. ARMY AVIATION AND TROOP COMMAND  
ATTN: AMSAT-I-MP  
4300 GOODFELLOW BOULEVARD  
ST. LOUIS, MO 63120-1798

TEAR ALONG PERFORATED LINE

**RECOMMENDED CHANGES TO EQUIPMENT TECHNICAL PUBLICATIONS**

**SOMETHING WRONG WITH THIS PUBLICATION?**



**THEN . . . JOT DOWN THE DOPE ABOUT IT ON THIS FORM. CAREFULLY TEAR IT OUT. FOLD IT AND DROP IT IN THE MAIL!**

**FROM: (PRINT YOUR UNIT'S COMPLETE ADDRESS)**

**DATE SENT**

**PUBLICATION NUMBER**

TM 5-4320-301-13&P

**PUBLICATION DATE**

6 JAN 86

**PUBLICATION TITLE** FORWARD AREA WATER POINT SUPPLY SYSTEM (FAWPSS) MODEL WPSS100 AND MODEL 9095-91

**BE EXACT . . . PIN-POINT WHERE IT IS**

PAGE NO	PARA-GRAPH	FIGURE NO	TABLE NO
---------	------------	-----------	----------

**IN THIS SPACE TELL WHAT IS WRONG AND WHAT SHOULD BE DONE ABOUT IT:**

TEAR ALONG PERFORATED LINE

**PRINTED NAME, GRADE OR TITLE, AND TELEPHONE NUMBER**

**SIGN HERE.**

**DA FORM 2028-2**  
1 JUL 79

PREVIOUS EDITIONS ARE OBSOLETE.  
DRSTS-M Overprint 2, 1 Nov 80.

**P.S.--IF YOUR OUTFIT WANTS TO KNOW ABOUT YOUR RECOMMENDATION MAKE A CARBON COPY OF THIS AND GIVE IT TO YOUR HEADQUARTERS.**

1 Nov 80

FILL IN YOUR  
UNITS ADDRESS



FOLD BACK

DEPARTMENT OF THE ARMY

---

---

OFFICIAL BUSINESS

COMMANDER  
U.S. ARMY AVIATION AND TROOP COMMAND  
ATTN: AMSAT-I-MP  
4300 GOODFELLOW BOULEVARD  
ST. LOUIS, MO 63120-1798

TEAR ALONG PERFORATED LINE

# The Metric System and Equivalents

## Linear Measure

1 centimeter = 10 millimeters = .39 inch  
 1 decimeter = 10 centimeters = 3.94 inches  
 1 meter = 10 decimeters = 39.37 inches  
 1 dekameter = 10 meters = 32.8 feet  
 1 hectometer = 10 dekameters = 328.08 feet  
 1 kilometer = 10 hectometers = 3,280.8 feet

## Weights

1 centigram = 10 milligrams = .15 grain  
 1 decigram = 10 centigrams = 1.54 grains  
 1 gram = 10 decigrams = .035 ounce  
 1 dekagram = 10 grams = .35 ounce  
 1 hectogram = 10 dekagrams = 3.52 ounces  
 1 kilogram = 10 hectograms = 2.2 pounds  
 1 quintal = 100 kilograms = 220.46 pounds  
 1 metric ton = 10 quintals = 1.1 short tons

## Liquid Measure

1 centiliter = 10 milliliters = .34 fl. ounce  
 1 deciliter = 10 centiliters = 3.38 fl. ounces  
 1 liter = 10 deciliters = 33.81 fl. ounces  
 1 dekaliter = 10 liters = 2.64 gallons  
 1 hectoliter = 10 dekaliters = 26.42 gallons  
 1 kiloliter = 10 hectoliters = 264.18 gallons

## Square Measure

1 sq. centimeter = 100 sq. millimeters = .155 sq. inch  
 1 sq. decimeter = 100 sq. centimeters = 15.5 sq. inches  
 1 sq. meter (centare) = 100 sq. decimeters = 10.76 sq. feet  
 1 sq. dekameter (are) = 100 sq. meters = 1,076.4 sq. feet  
 1 sq. hectometer (hectare) = 100 sq. dekameters = 2.47 acres  
 1 sq. kilometer = 100 sq. hectometers = .386 sq. mile

## Cubic Measure

1 cu. centimeter = 1000 cu. millimeters = .06 cu. inch  
 1 cu. decimeter = 1000 cu. centimeters = 61.02 cu. inches  
 1 cu. meter = 1000 cu. decimeters = 35.31 cu. feet

## Approximate Conversion Factors

To change	To	Multiply by	To change	To	Multiply by
inches	centimeters	2.540	ounce-inches	newton-meters	.007062
feet	meters	.305	centimeters	inches	.394
yards	meters	.914	meters	feet	3.280
miles	kilometers	1.609	meters	yards	1.094
square inches	square centimeters	6.451	kilometers	miles	.621
square feet	square meters	.093	square centimeters	square inches	.155
square yards	square meters	.836	square meters	square feet	10.764
square miles	square kilometers	2.590	square meters	square yards	1.196
acres	square hectometers	.405	square kilometers	square miles	.386
cubic feet	cubic meters	.028	square hectometers	acres	2.471
cubic yards	cubic meters	.765	cubic meters	cubic feet	35.315
fluid ounces	milliliters	29.573	cubic meters	cubic yards	1.308
pints	liters	.473	milliliters	fluid ounces	.034
quarts	liters	.946	liters	pints	2.113
gallons	liters	3.785	liters	quarts	1.057
ounces	grams	28.349	liters	gallons	.264
pounds	kilograms	.454	grams	ounces	.035
short tons	metric tons	.907	kilograms	pounds	2.205
pound-feet	newton-meters	1.356	metric tons	short tons	1.102
pound-inches	newton-meters	.11296			

## Temperature (Exact)

°F	Fahrenheit temperature	5/9 (after subtracting 32)	Celsius temperature	°C
----	------------------------	----------------------------	---------------------	----

